

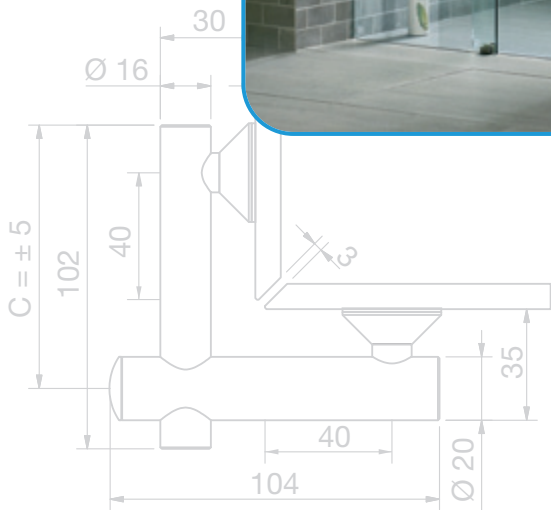

Vivere II

Pare-douche coulissant
sliding door system for glass showers



Information Technique
technical information



Vivere II: une élégance fonctionnelle – *functional Elegance*

Un excellent design est non seulement attirant, il vous convainc également par son élégance intemporelle et sa fonctionnalité sophistiquée. Vivere II répond à ces revendications. D'une part grâce à ses harmonieuses formes arrondies qui feront l'originalité de votre salle de bain carrée, d'autre part, par ses modèles variés et individualisés qui s'adaptent à toute forme d'installation.

Excellent design is not only attractive – it convinces with timeless elegance and well-thought-out functionality.

Vivere II meets those demands. On one hand by its harmonic round shape, which forms a highlight in a squared bathroom, and on the other hand by its individually adjustable construction, that adapts perfectly to any current installation situation.



■ Les salles de bain à l'italienne sont de plus en plus appréciées.

Rien d'étonnant à cela, car elles offrent de nombreux avantages et ainsi une meilleure qualité de vie. Ainsi les solutions pour des salles de bains ouvertes avec Vivere, sont simples et faciles à réaliser.

Barrier-free bathrooms are getting more popular.

Not surprising, as they provide real practical advantages and subsequently a better quality of life.

Vivere II is not only a smooth solution for barrier-free baths, but also a very attractive one.

■ Made in Germany, Acier inoxydable

Nos produits en acier inoxydable sont usinés sur des machines CNC les plus récentes. Nos tolérances de fabrication garantissent une qualité et une sécurité dimensionnelle.

Our stainless steel products are being processed on most modern CNC lathes and milling machines. Tight producing tolerances grant a maximum dimensional accuracy and quality.



Le montage: simple et adaptable/assembly: easy and versatile



- Ajustement du vantail coulissant :**
 Grâce à ces galets excentriques, la hauteur et l'inclinaison du panneau de verre peuvent être ajustées avec la clé à ergot (art n° Z058)
Due to the eccentric guiding rollers the glass panel can be adjusted in height and incline by a face spanner (art. no. Z058) when assembling the shower.



- Quatre solutions :**
 Chaque montage est différent, ainsi nous vous proposons dans notre nouveau catalogue, 4 fixations murales différentes adaptées à votre besoin./Not every built-in situation offers the same preconditions. Therefore, the Vivere II range offers 4 different possibilities of wall connections.



- Fixation plafond design :**
 A monter pour des longueurs de côté supérieures à 1000mm, pour un rail simple./practical ceiling hanger recommended for showers with a leg length of more than 1000mm. For single-tube application only



- Fermeture de la porte en douceur :**
 L'amortisseur peut être réglé après montage pour les rails simples, afin de permettre une fermeture en douceur.
Soft closing buffers. They can be readjusted for a smooth closing. Only for single tube.

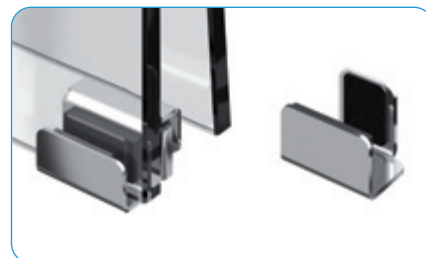

- Solutions spéciales:**
 Bien que les versions standard de Vivere II proposent de nombreuses applications, grâce à des variantes et des solutions particulières nous vous proposons une grande variété d'adaptations. Elles permettent la mise en oeuvre de Vivere II dans des applications inhabituelles ou la réalisation de douches à l'italienne/ Besides our standard versions of Vivere II we are offering a comprehensive variety of possible designs when using our special solutions. Variable solutions enable you to design extraordinary built-in situations or to create a barrier-free bathroom.



- Guide au sol amovible.**
 Le vantail peut être décroché sans outillage. Les éléments magnétiques se détachent par une légère traction de la porte jusqu'à la butée (aprox, 3mm), ainsi le coulissant peut être écarté du fixe. Ce système de guide est adapté au porte droites ou bombées.
floor guide can be unhinged
The glass sliding door can be released without tools. The magnets can be untightened by pulling slightly at the door part to the guide stopper (about 3mm). Then you can pull the door guide off the bracket. Bracket suitable for straight or curved glass panel.



Plus de produits + d'accessoires/*more products + accessoires*



7772VA Fixation verre-mur 90°, en saillie/*fastener raised head*



7773VA Fixation verre-mur 90°, affleurée/*fastener flush*



7774VA Connecteur d'angle verre-verre, 90°, en saillie/*fastener raised head*



7775VA Connecteur d'angle verre-verre, 90°, affleurée/*fastener flush*



7777VA Connecteur verre-verre, 180°, en saillie/*connector raised head*



7778VA Connecteur verre-verre, 180°, affleurée/*connector flush*



8526VAL Guide au sol gauche/*floor guide left*



8526VAR Guide au sol droit/*floor guide right*



8517VA Douille, fixation murale/*wall stud*



8547VA Adaptateur mural/*wall connector*



8576VAL/R Fixation murale/*wall connection*



8505VA Profil en U/*U-profile*



8544VA Fixation plafond/*ceiling hanger*



8545VA Fixation plafond/*ceiling hanger*



31290VA-6M Rail inox/*stainless steel tube*



8513VA Rail anti-dégondage/*jump retainer*



8515VA Angle à 90° pour rail simple ou rail double haut/*corner piece 90° for single and lower double current tube*



8516VA Angle à 90° pour rail double bas/*corner piece 90° for double current tube*



8509VA Stoppeur pour rail double/*stopper for double current tube*



8542VA Stoppeur pour rail simple/*stopper for single current tube*



8548VA Galet excentrique/*eccentric slide wheel*



8546VA Bouchon Ø30mm/*end plug Ø 30 mm*



8543VA-8 Pince ronde Ø30mm/*round clamp Ø30mm*



8543VA-8-90 Pince ronde Ø30mm/*round clamp Ø30mm*



8502VA Bouton de porte/*glass door knob*



8298VA Bouton de porte/*glass door knob*



32028VA-8 Bouton évidé/*Recess knob*



8546VA Poignée double/*door handle*

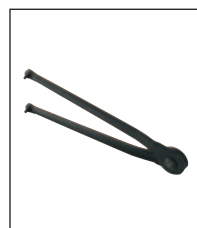

Z058 Clé à ergot Ø3/*face spanner Ø3*



Z059 Clé à ergot Ø2,5/*face spanner Ø2,5*

Montage facile/*Easy assembly*

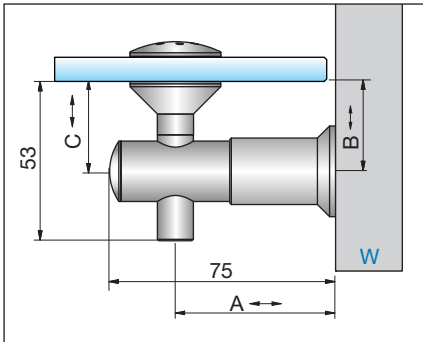

■ **Fixation murale réglable dans les 3 dimensions :**

Les fixations murales ont un réglage de: A= +ou- 3mm
B= +ou - 4mm (trou oblong)
C= +ou- 8mm

Ceci vous permet un meilleur ajustement/*The angular connectors are adjustable at A: ± 3 mm, at B: ± 8 mm and at C: ± 8mm (oblong hole). This enables a better vernier adjustment.*

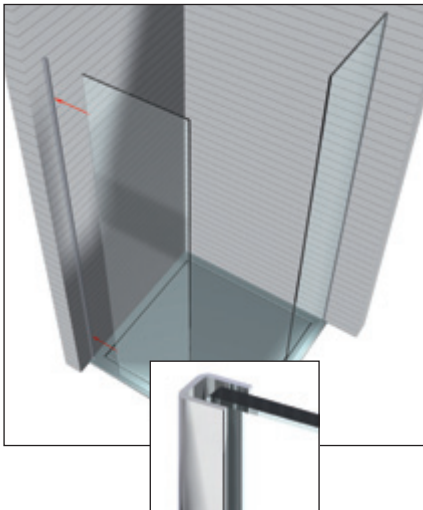

Application avec profil en U

- épaisseurs de verre 8 à 10mm
- longueurs de 1980 à 5000mm
- matériau : acier inoxydable

Application with U-profile

- for glass thickness 8, 12 und 15 mm
- for lengths from 1980 – 5000 mm
- Material: A2 (1.4301)

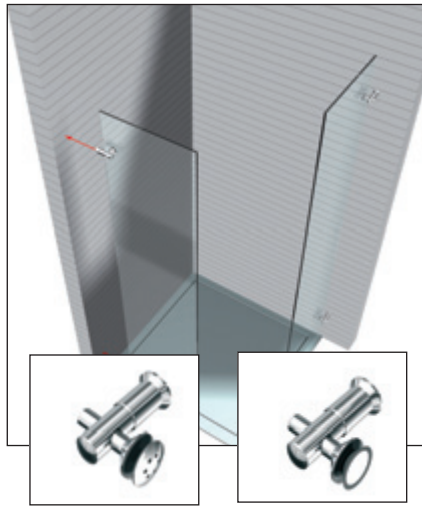

Application avec fixation murale

- épaisseur de verre de 8 à 10mm
- en saillie ou affleurant
- matériau : acier inoxydable

Application with wall fastener

- for glass thickness 8 – 12 mm
- flush or raised head
- Material: A2 (1.4301)



Fixation murale du rail :

- fixation alternative avec plaque de fixation
- matériau : acier inoxydable

wall mount plate

- alternative wall mount plate with pin
- Material: A2 (1.4301)

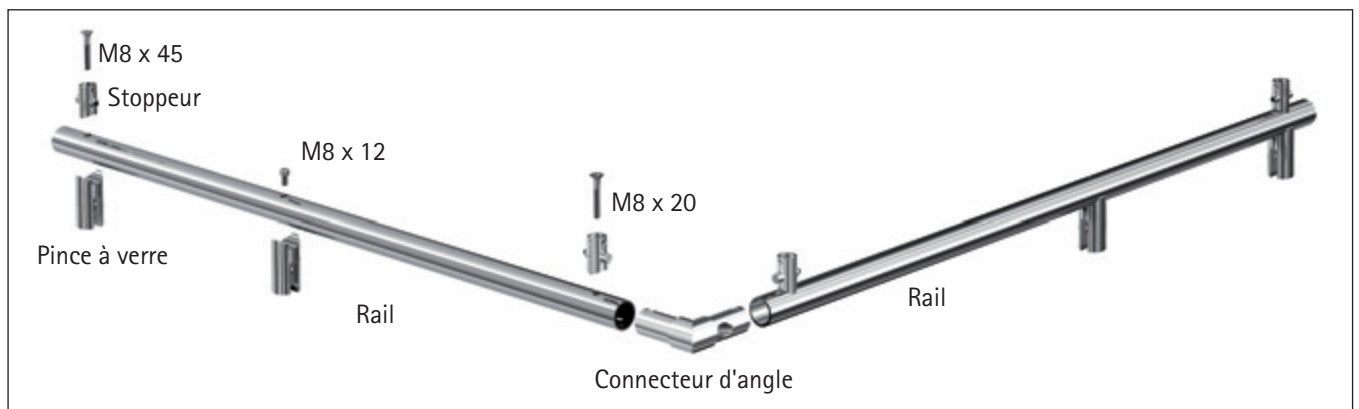

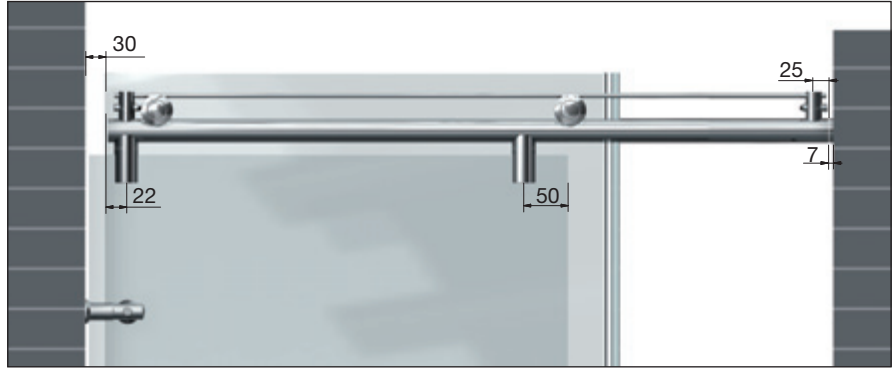

Exemple : douche encastrée, rail simple

Les dimensions jusqu'à une largeur de 1200mm peuvent être réalisées avec nos douches 8563VA-V, 8564VA-V et 8565VA-V. Au delà de 1200mm jusqu'à 2000mm nous vous conseillons les modèles 8557VA-V, 8558VA-V et 8559VA-V avec un rail double.

example niche shower with single current tube:

For niche widths of up to 1200mm you can use our shower 8563VA-V, 8564VA-V and 8565VA-V. For niche widths of 1200-2000mm we recommend to use our shower 8557VA-V, 8558VA-V and 8559VA-V with double rail.

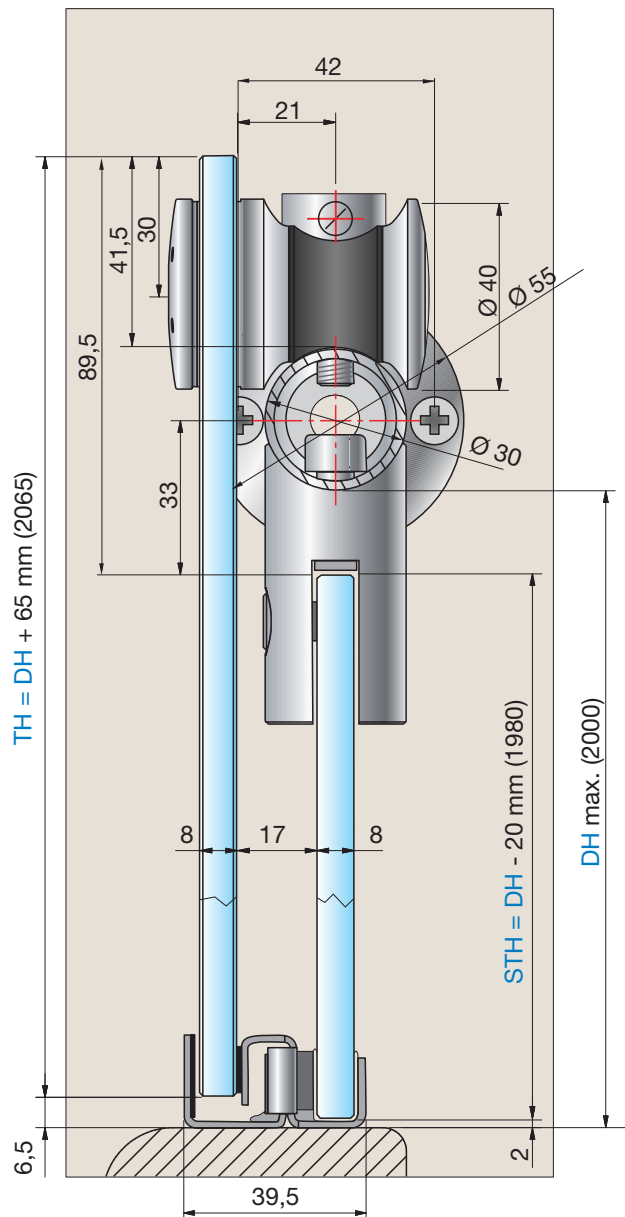
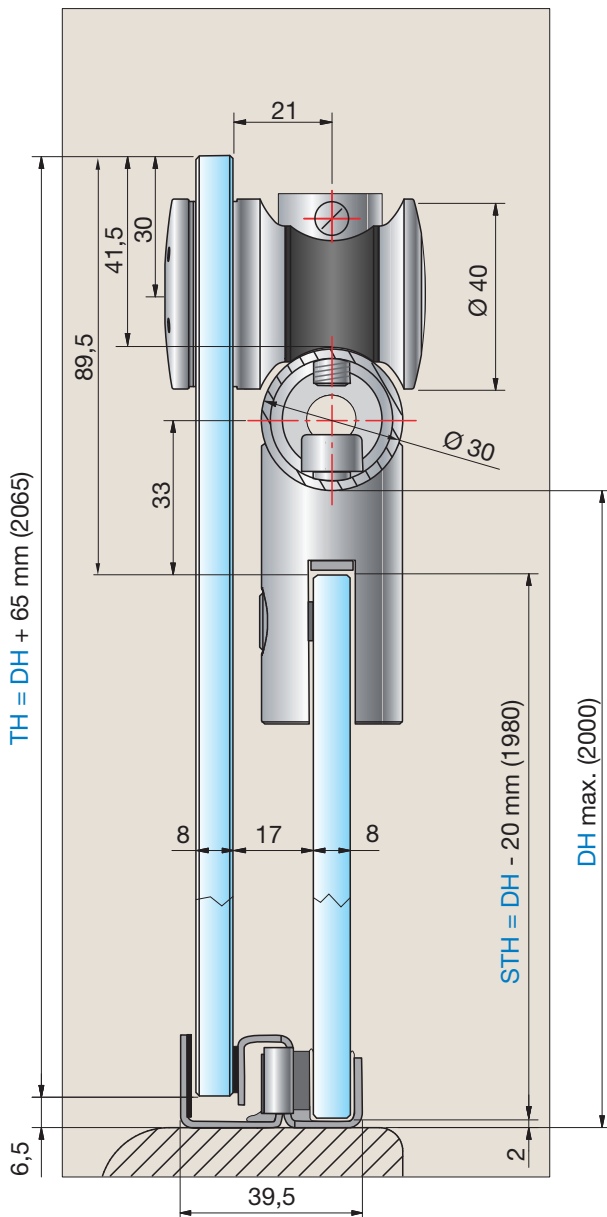

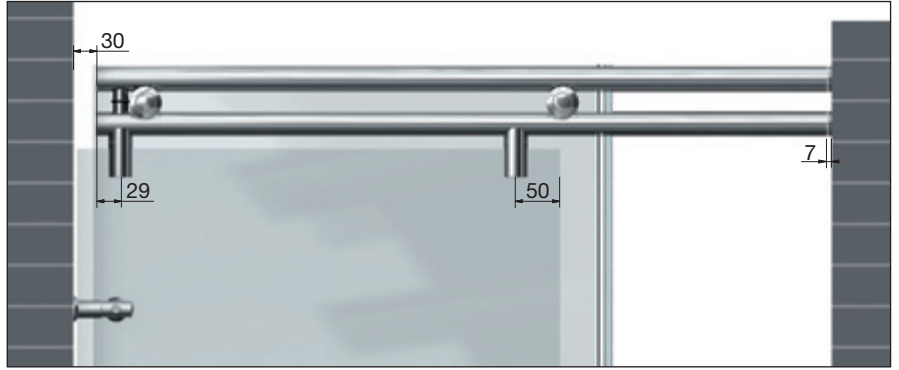

Exemple : douche encastrée avec rail double
Vous pouvez choisir la fixation murale adaptée à votre configuration, soit une douille (8517VA) ou une plaque (31177VA). Fixation standard : douille 8517VA.

example niche shower with double current tube:
Shower cabinet solutions are alternatively available with wall stud (8517VA) or wall connector plate (31177VA). (Standard: wall stud 8517VA)

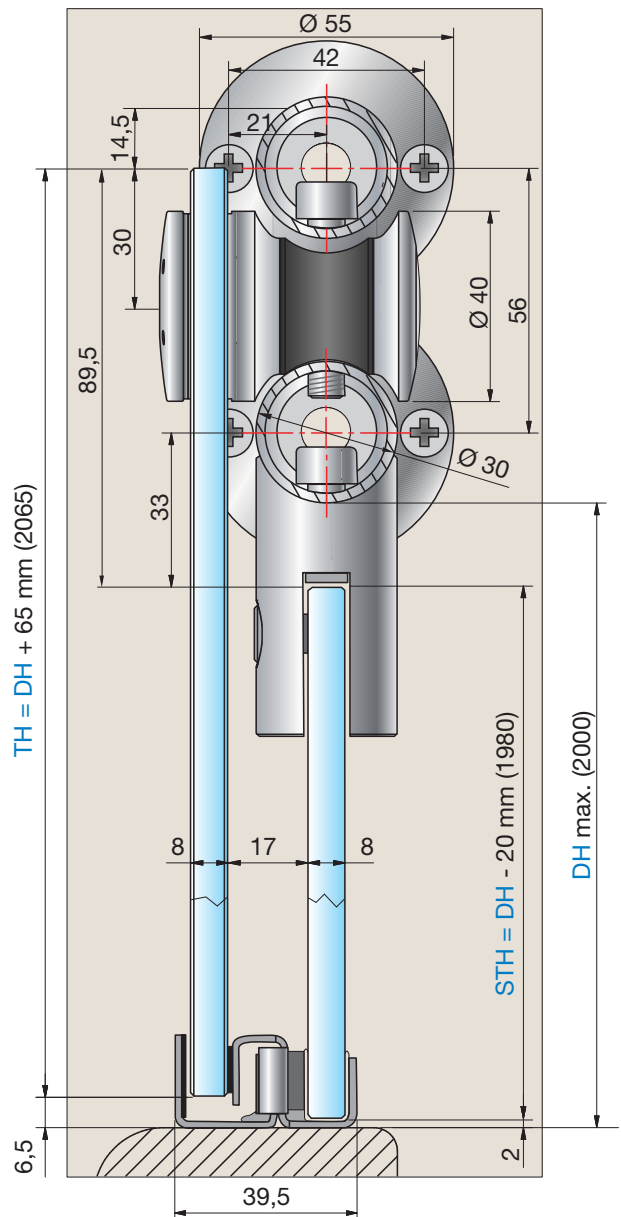
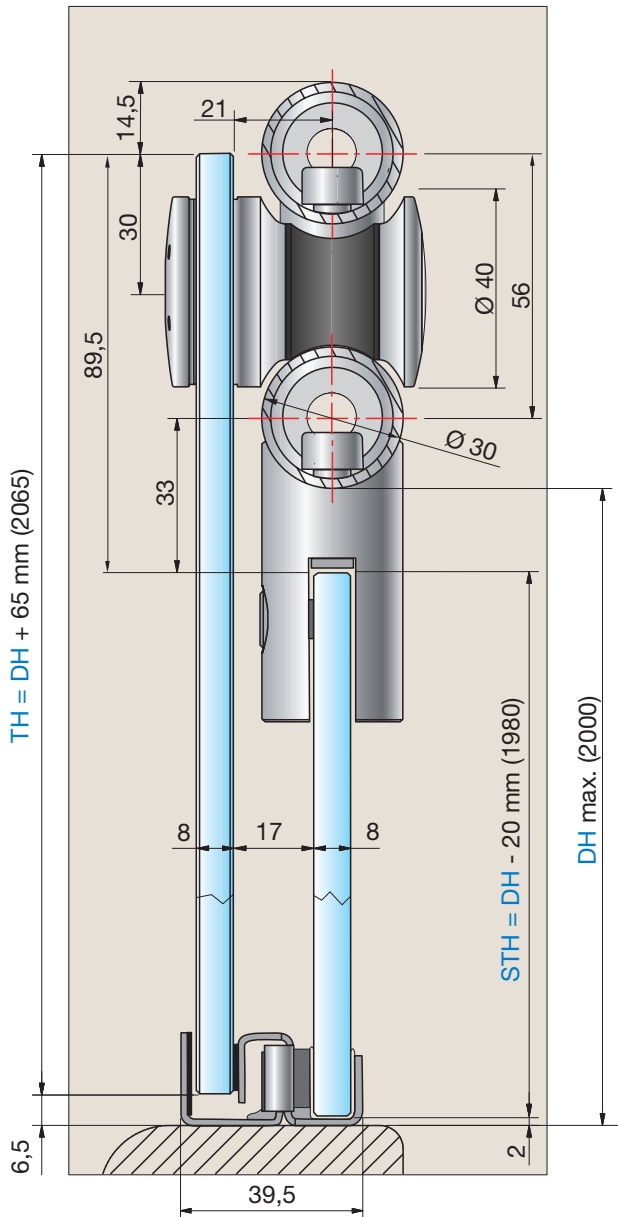

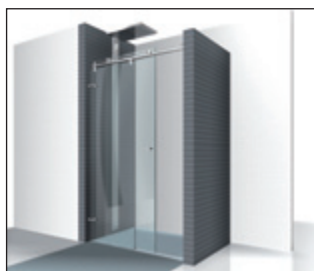

Douche encastrée 8563 à 8565VA-V
niche shower 8563 up to 8565VA-V

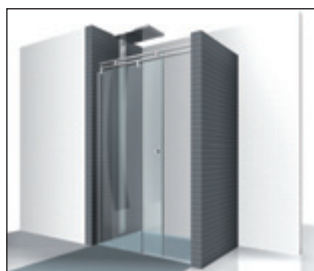

Douche encastrée 8557 à 8559VA-V
niche shower 8557 up to 8559VA-V

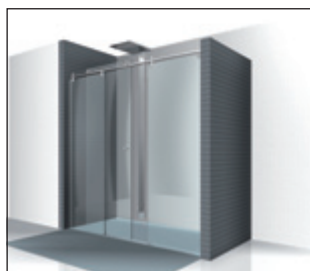

Douche encastrée 8549VA-V
niche shower 8549VA-V

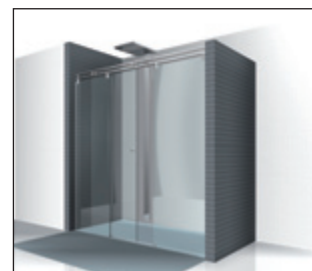

Douche encastrée 8552VA-V
niche shower 8552VA-V

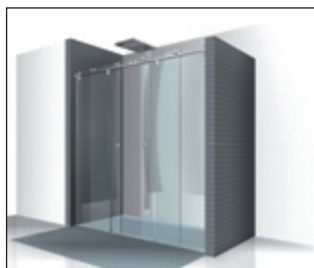

Douche encastrée 8551VA-V
niche shower 8551VA-V

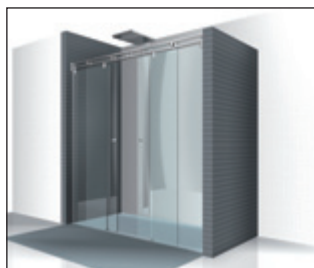

Douche encastrée 8553VA-V
niche shower 8553VA-V

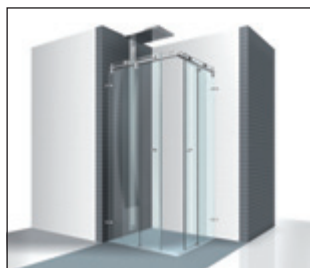

Douche d'angle 8560 à 8562VA-900
corner shower 8560 up to 8562VA-900



Douche d'angle 8560 à 8562VA-1000
corner shower 8560 up to 8562VA-1000



Douche d'angle 8560 à 8562VA-V
corner shower 8560 upto 8562VA-V

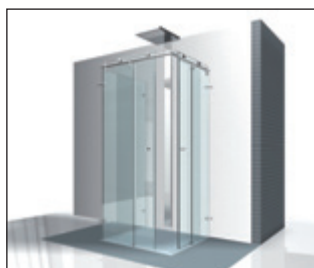

Douche en U 8566 à 8567VA-V
u-shower 8566 up to 8567VA-V



Quart de rond 8570VA
circular shower 8570VA



Quart de rond 8571VA
circular shower 8571VA



Quart de rond 8572VA
circular shower 8572VA



Douche ronde 8522VA
circular shower 8522VA



* Douche d'angle 8554VA-V
corner shower 8554VA-V



* Douche d'angle 8555VA-V
corner shower 8555VA-V

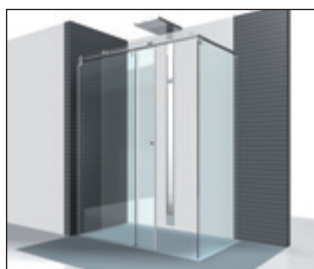

* Douche d'angle 8568VA-V
corner shower 8568VA-V



* Douche d'angle 8556VA-V
corner shower 8556VA-V

* Construction spéciale/ special construction