

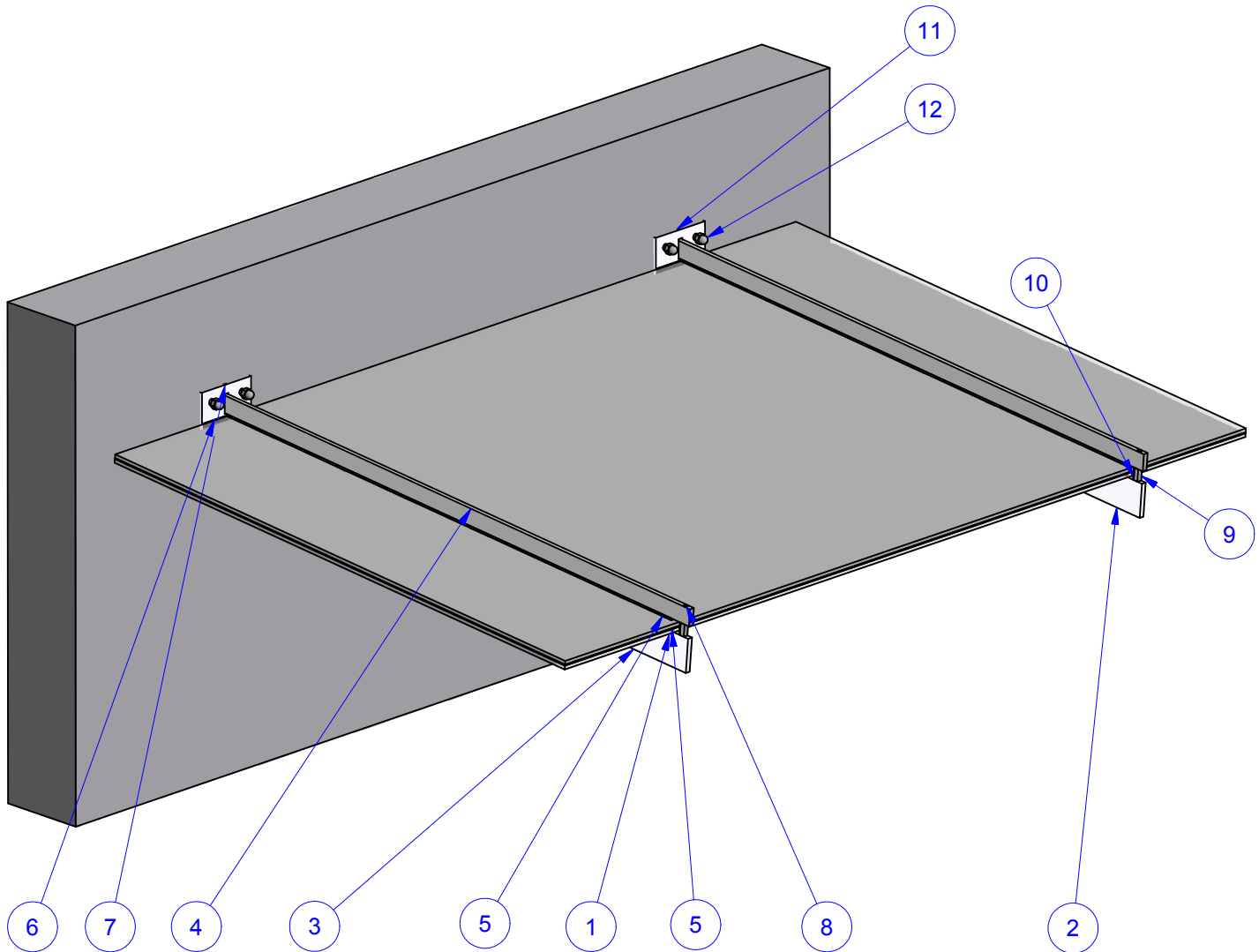

MA 1715VA "King-II"

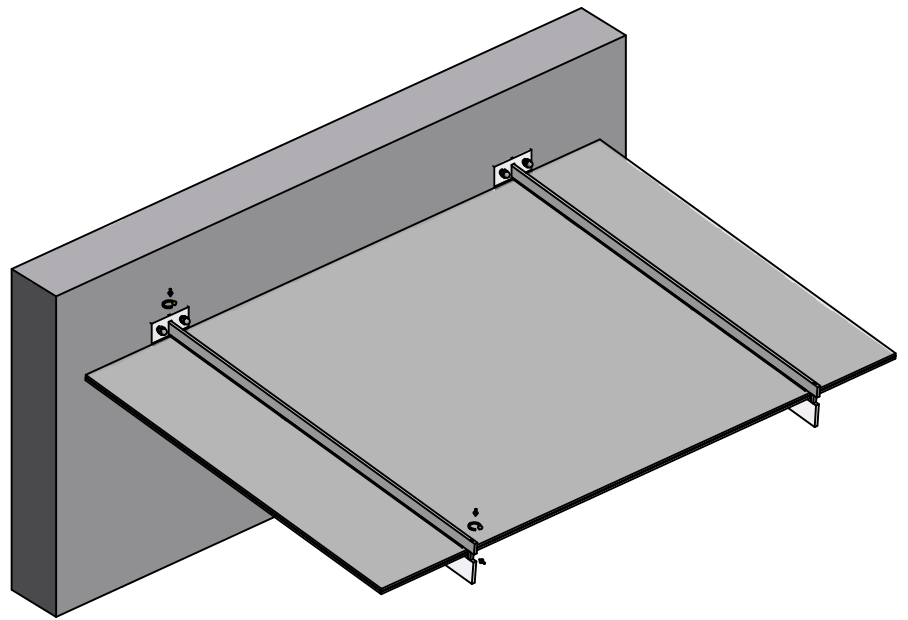

Position	Stück	Artikel-Nr.	BEZEICHNUNG	MATERIAL
1	1	1715VA_VSG16	Glas zu 1715VA, 2er SET, 1800x1200x17,52	VSG16 ; 2x8mm TVG mit PVB-Folie 1,52mm
2	2	1713VA-1	Ausleger Vordach "King2", komplett, V1	
3	1	1716-1VA	Ausleger Vordach "King2", "NEU"	1.4301 (304) geschweißt
4	1	1716-2VA	Deckleiste Vordach "King2", "NEU"	1.4301 (304)
5	2	1716-4EPDM	EPDM zu Vordach King2 "NEU", 118x10x4mm	EPDM schwarz (Shore A 80)
6	1	1716-5EPDM	EPDM zu Vordach King2 "NEU", 128x20x2mm	EPDM schwarz (Shore A 80)
7	1	S913A2D6x16	Gewindestift DIN 913 - M6 x 16 - A2	A2
8	1	S912A2D5x65	Zylinderschraube DIN 912 - M5 x 65 - A2	A2
9	1	1716-4VA	Distanzhülse vierkant für King 2"NEU"	1.4301 (304)
10	1	1716-6EPDM	EPDM zu Vordach King2 "NEU", 24x10x2mm	EPDM schwarz (Shore A 80)
11	8	S913A4D12x80	Gewindestift DIN 913 - M12 x 80 - A4	A4
12	8	S1587A2D12 SW 18	Hutmutter DIN 1587 - M12 - SW 18	A2



Beim Bohrvorgang der Anschraublöcher zur Wandmontage, muß eine horizontale Ausrichtung der Gewindefestigungen zueinander gewährleistet sein.

It is imperative to ensure an exact horizontal axis between the pilot holes for the threaded rods.

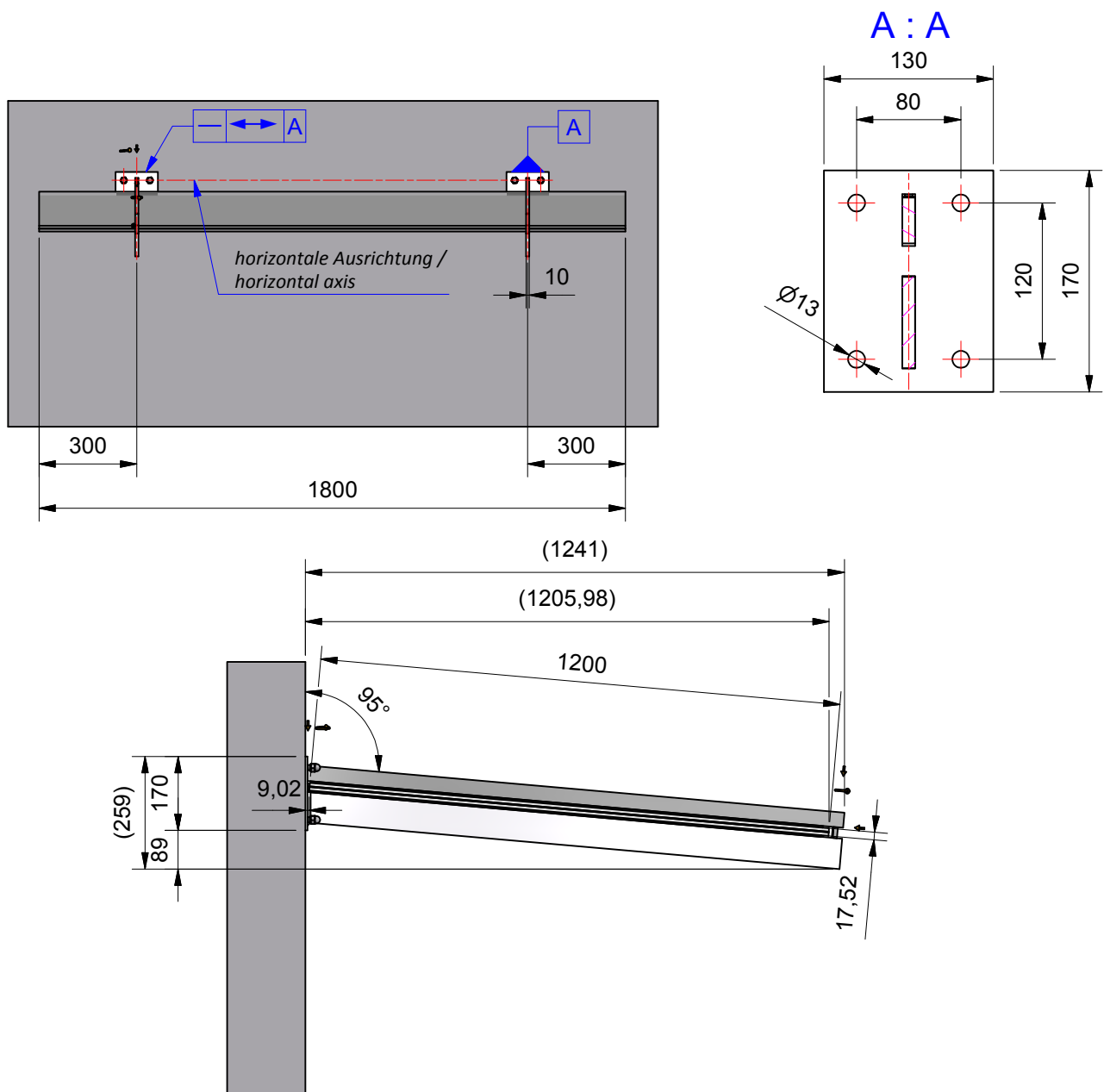



+49 2291 9206 0

England

Frankreich

Italien

Japan

Niederlande

Österreich

+46 8 449 32 00

Schweiz

Spanien

USA

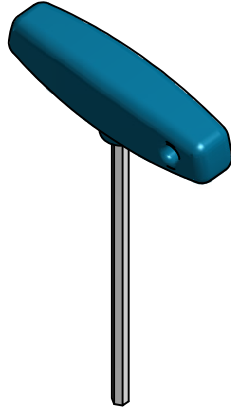

5 mm

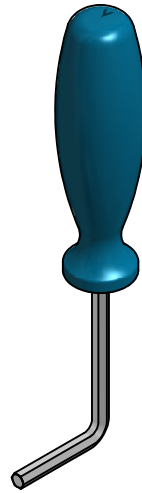

3 mm

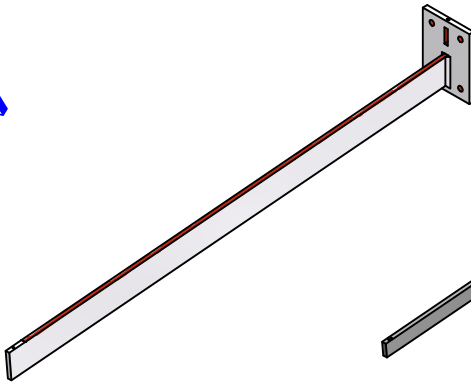

2 x
1716-1VA

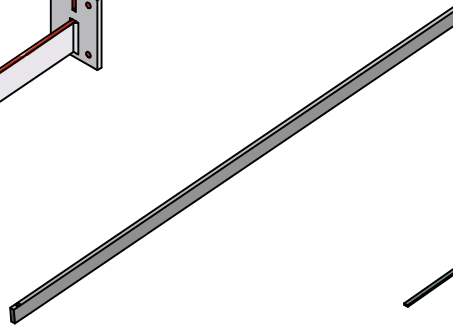

2 x
1716-2VA

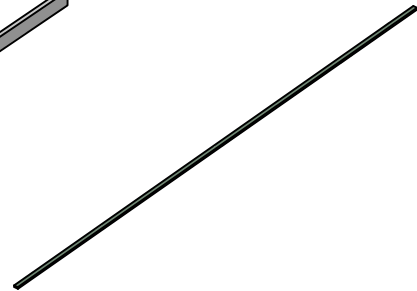

4 x
1716-4EPDM
(bereits bei P&S verklebt)

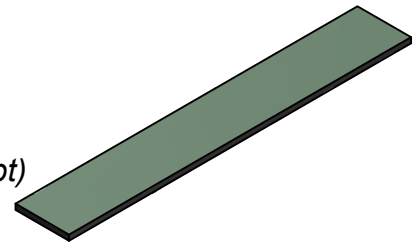

2 x
1716-5EPDM
(bereits bei P&S verklebt)



2 x
1716-4VA



2 x
1716-6EPDM
(bereits bei
P&S verklebt)



2 x
S913A2D6x16

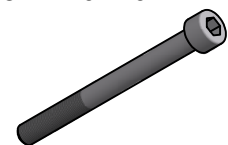

2 x
S912A2D6x65

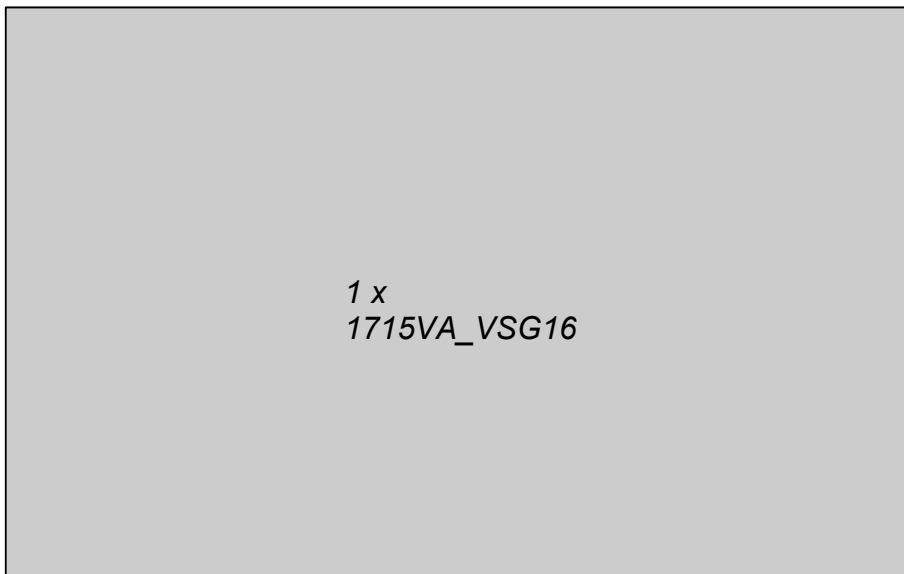

1 x
1715VA_VSG16



1.

Im ersten Montageschritt müssen die Ausleger mit dem für den Befestigungsuntergrund entsprechenden Befestigungsmaterial an der Wand angeschraubt werden.

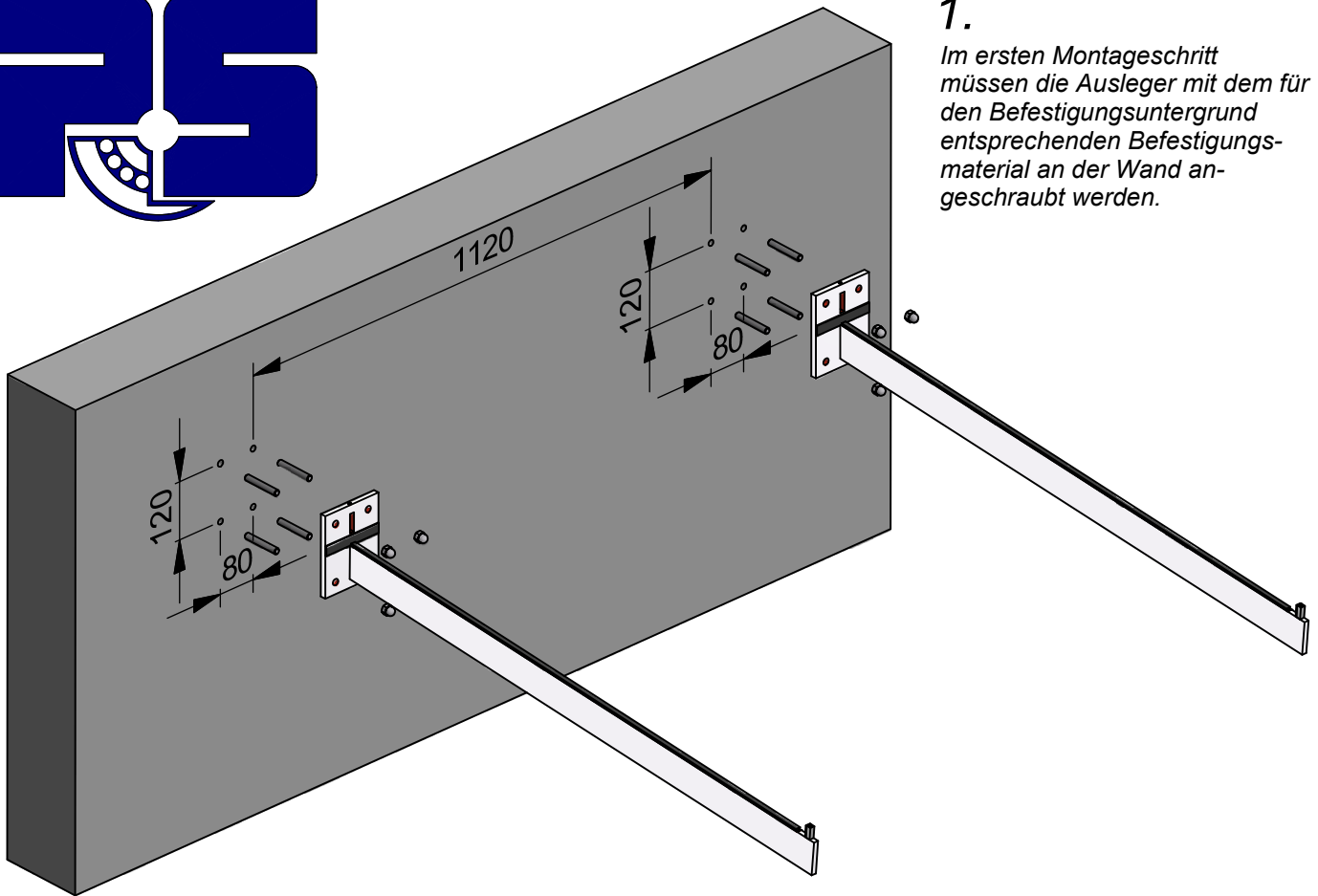

3.

Im dritten Montageschritt kann die obere Abdeckleiste aufgelegt werden im verschraubt werden.

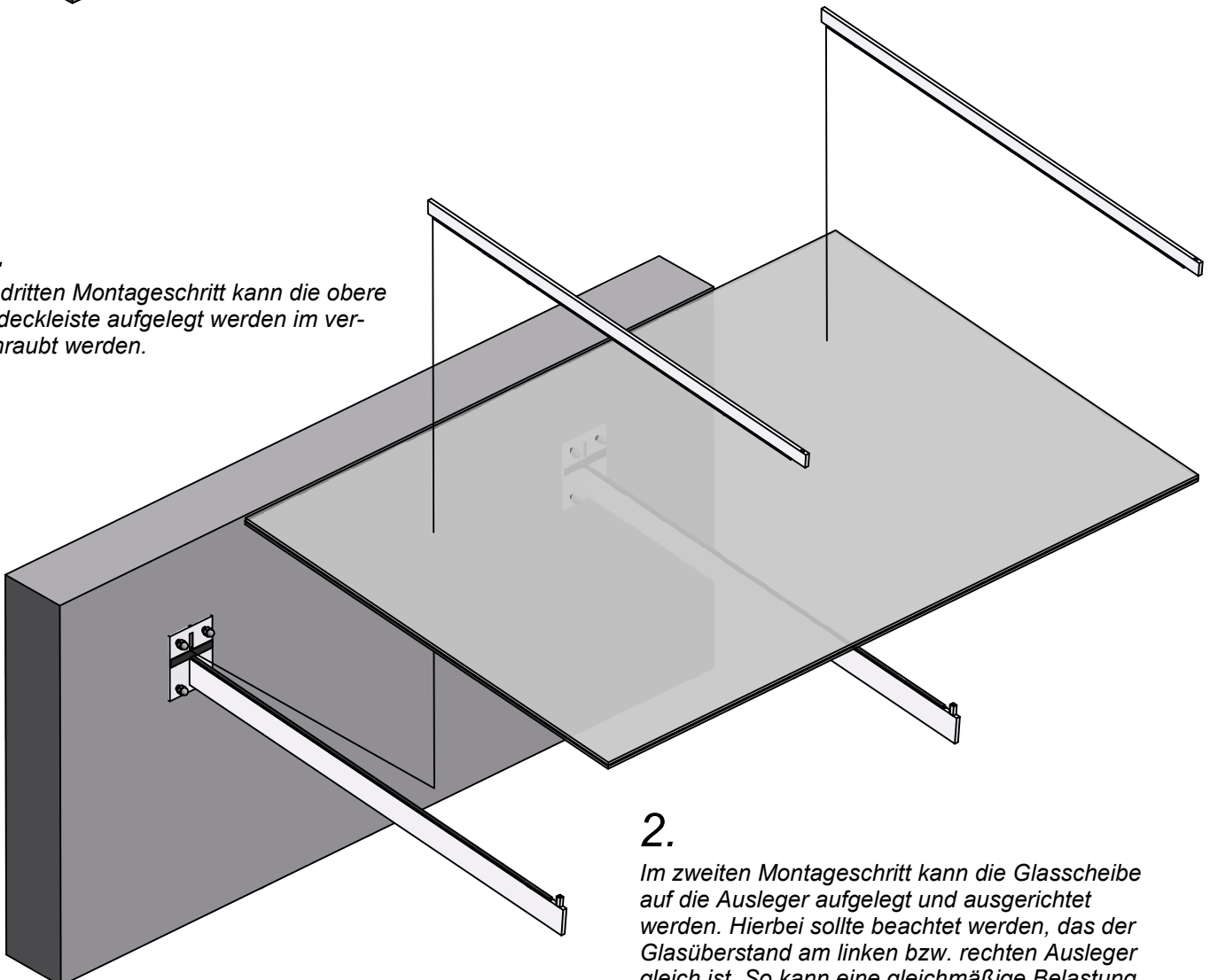

2.

Im zweiten Montageschritt kann die Glasscheibe auf die Ausleger aufgelegt und ausgerichtet werden. Hierbei sollte beachtet werden, dass der Glasüberstand am linken bzw. rechten Ausleger gleich ist. So kann eine gleichmäßige Belastung der Ausleger gewährleistet werden.

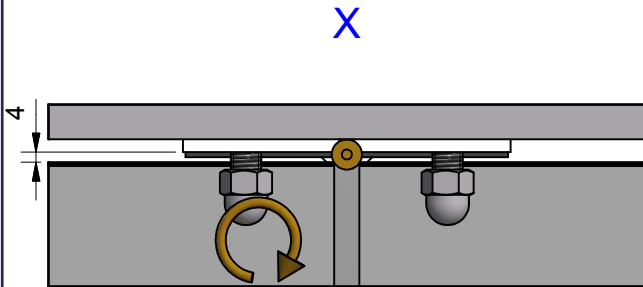
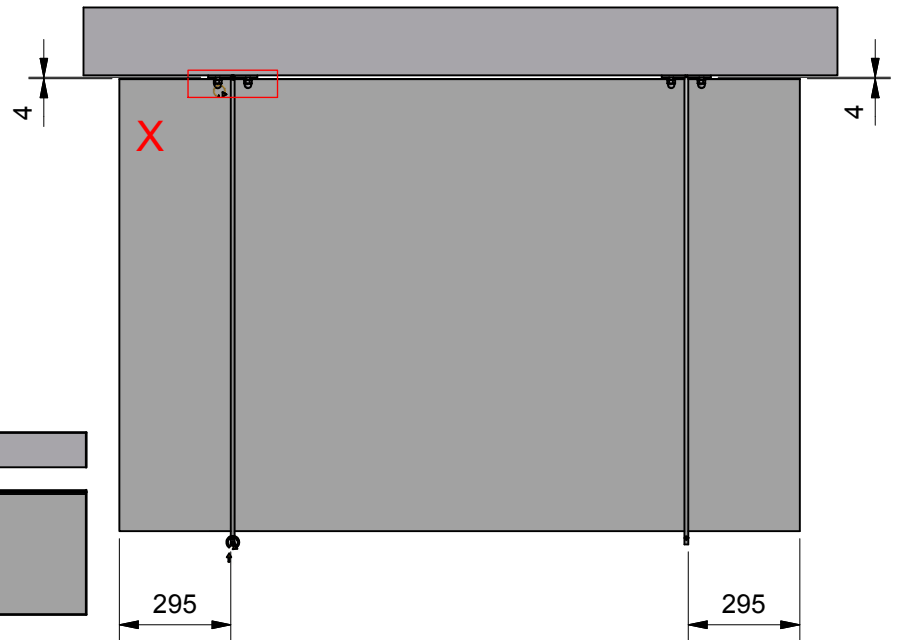

Die Befestigungsschrauben soweit hineinschrauben, bis es zu einem Kontakt zwischen oberer Deckleiste und Glasscheibe kommt. Im weiteren Verlauf, die Schrauben nur noch soweit anziehen, das die obere Deckleiste sich in ihrer Form (Bogen im mittleren Bereich) nicht verbiegt.

Empfehlung : Schrauben abwechselnd anziehen !!!

Insert and turn the screws until there is slight contact of the glass pane and the clamping bracket .Tighten the screws slowly so that the contact along the entire clamp bracket is ensured and does not bow in the middle.

Recommendation: tighten the screws alternately!

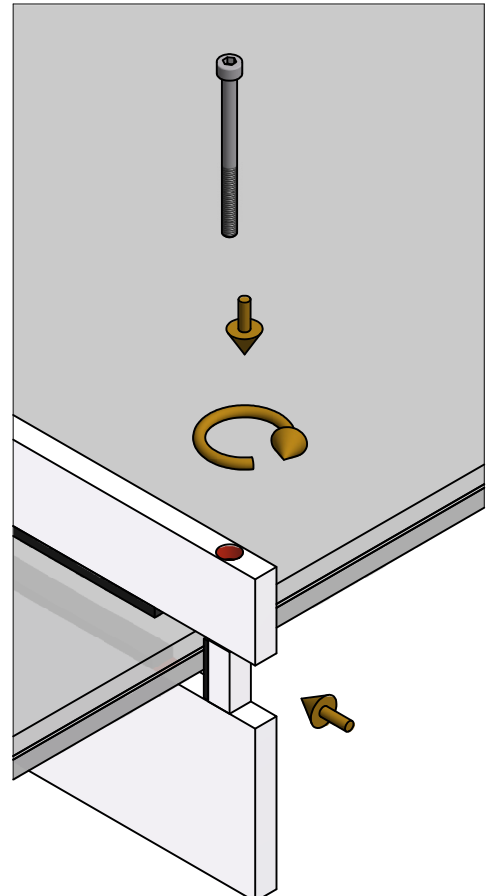
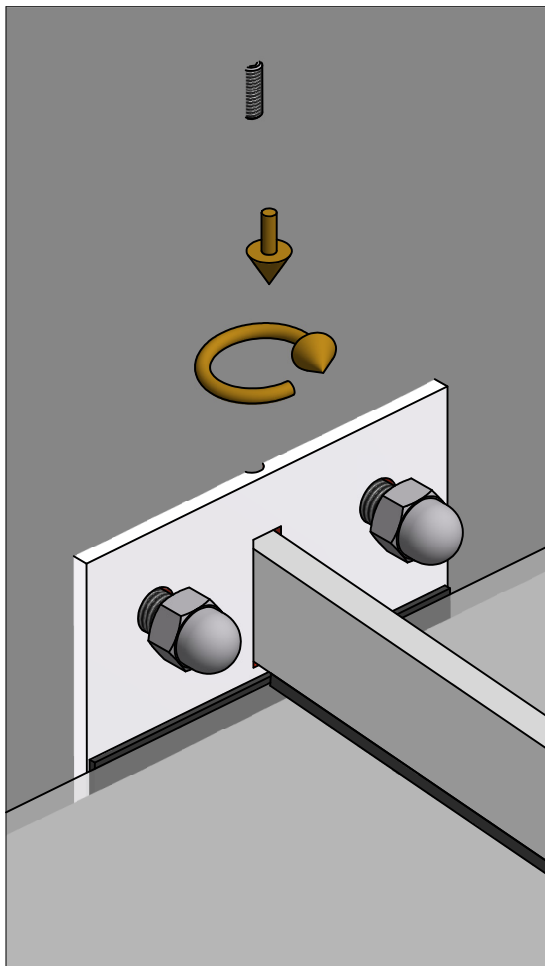



Bitte die Übereinstimmungserklärung ausfüllen und dem Bauherren übergeben!
Please, fill in the conformity description and hand it over to the building owner!

Übereinstimmungserklärung des Montageunternehmens/
Conformity description of the assembling company

Ergänzend zum Übereinstimmungsnachweis des Herstellers der Haltekonstruktion und der VSGScheiben, muss vom Montageunternehmen eine schriftliche Übereinstimmungserklärung erfolgen, dass die Ausführung des Vordachsystems den Bestimmungen dieser allgemeinen bauaufsichtlichen Zulassung entspricht und die Montage entsprechend der Montageanleitung der Firma Pauli + Sohn GmbH erfolgt ist.

In addition to the conformity verification of the manufacturers of the wall mounts and the laminated safety glass panels, the assembling company has to make a conformity description in written form, stating that the construction of the canopy system is in accordance with the regulations of the national technical approval and that it has been assembled according to the assembly instruction of Pauli + Sohn GmbH.

Ausführung entsprechend der Montageanleitung durchgeführt./
The construction has been carried out in accordance with the assembly instruction.

Datum, Ort/
Date, place

Stempel/Unterschrift des Montageunternehmens/
stamp/signature of the assembling company

Empfangsbestätigung
Notice of receipt

Datum, Ort
Date, place

Stempel/Unterschrift des Bauherren/Verantwortlichen
stamp/signature of the building owner/Person in charge