

FARDELLO

ausdrucksstarkes Design

intelligent konstruiert

expressively and intelligently designed



MADE
IN
GERMANY



Pauli + Sohn

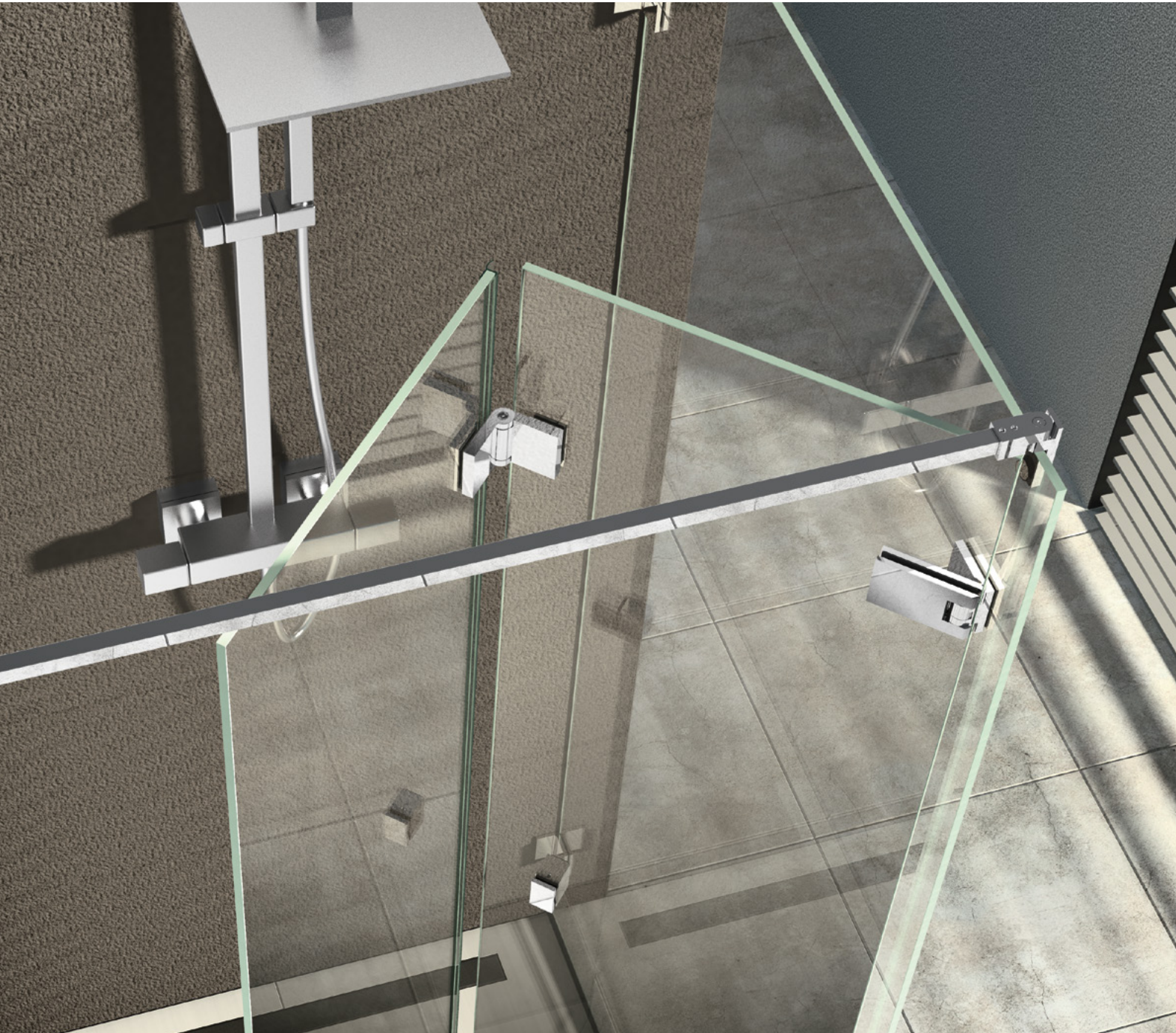

■ MADE
■ IN
■ GERMANY

Hohe Tragkraft für die moderne Badarchitektur

High load-bearing capacity for modern bathroom architecture

Das neue Duschpendeltürband FARDELLO zeichnet sich durch hohe Tragkraft und kompakte Maße aus. Bei einer Höhe von nur 56 mm tragen zwei Bänder maximal 42 kg. Möglich macht es die intelligente Konstruktion des Beschlags: Gegenplatte und Beschlagskorpus greifen formschlüssig ineinander und werden fest verschraubt. Das gewährt mehr Sicherheit. In der Kombination mit FLINTER lassen sich zudem verschiedene Falttüranlagen umsetzen.

The new FARDELLO shower swing door hinge is characterised by high

load capacity and compact dimensions. With a height of only 56 mm, two hinges carry a maximum load of 42 kg. This is made possible by the intelligent construction of the fitting: counter plate and hinge bodies interlock and create a firm screwed connection. This provides more safety. In combination with FLINTER, various folding door systems are possible.

- Tragfähigkeit (2 Bänder):
max. zulässiges Gewicht: 42 kg
max. Türflügelbreite: 1000 mm
Glasdicke: 6/8/10 mm
- Pendeltürband: Glas-Wand / Glas-Glas
- passende Winkelverbinder
- optimiert für die Verbauung ohne Dichtprofile
- minimierte Spaltmaße
- Nulllage stufenlos verstellbar
- Beschlaghöhe: 56 mm (wie FLAMEA- und FLINTER-Duschtürband)
- Anwendungsbereiche:
Wellnessbereich, barrierefreie Bäder, Objektbereiche
- load capacity (2 hinges):
max. permissible weight: 42 kg
max. door panel width: 1000 mm
glass thickness: 6/8/10 mm
- swing door hinge: glass-wall / glass-glass
- matching corner brackets
- optimized for installation without sealing profiles
- minimized gaps
- adjustable closed position
- hinge height 56 mm (like FLAMEA and FLINTER swing door hinge)
- areas of application:
wellness area, barrier-free bathrooms, commercial projects

technische Merkmale | technical features



Intelligent konstruiert:

Beschlagskorpus und Gegenplatte greifen formschlüssig ineinander und werden 4-fach fest verschraubt.

Intelligently designed:

The fitting body and counter plate interlock with each other and are firmly screwed together with 4 screws.

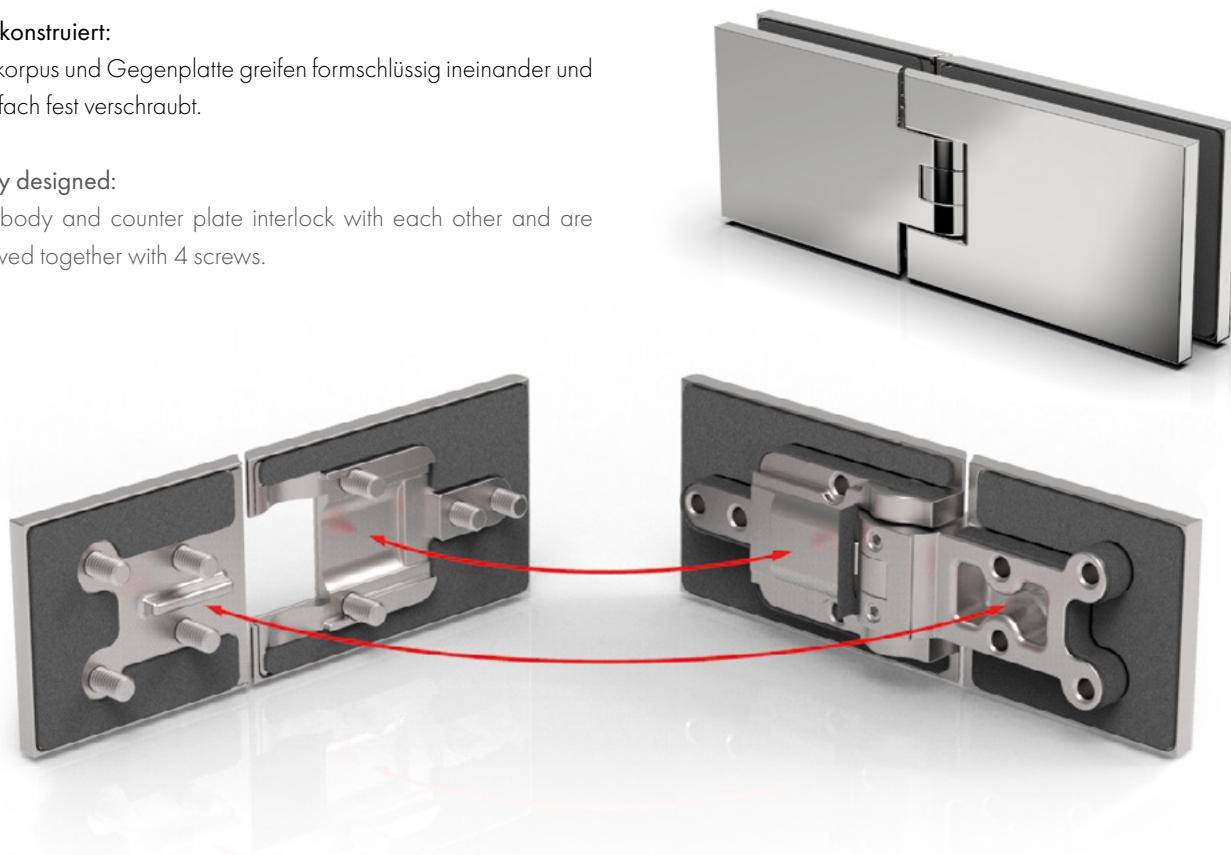

mit montagefreundlicher Abdeckung

Zum Fixieren der Abdeckkappen können diese mit den Zapfen schnell und sehr einfach in die vormontierten EPDM-Formteile gesteckt und andrückt werden. Um die Kappen gegen Diebstahl zu schützen, gibt es auch weiterhin Klebepunkte um sie zu fixieren.

with easy-to-install cover-plates

Attach the cover-plates by simply pressing the integrated studs into the pre-assembled EPDM retainer holes. To protect the cover-plates against theft, we offer double-sided adhesive pads to hold them in place.

technische Merkmale | technical features

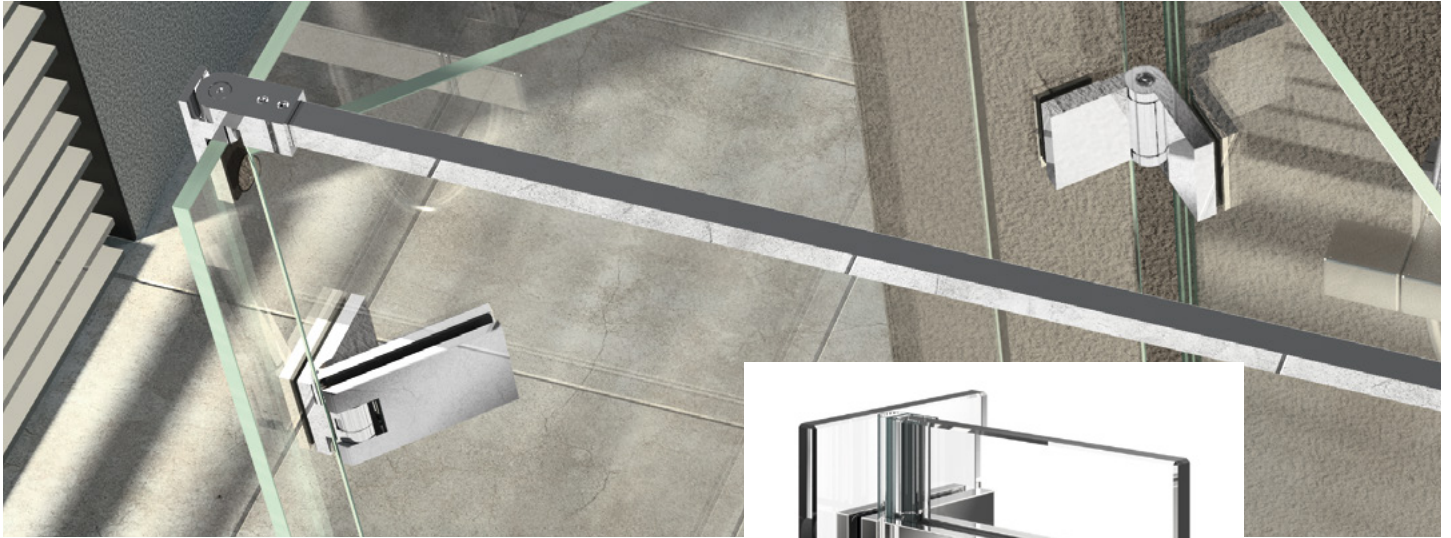

Beim Beschlag Glas-Glas 90° sind nur Glasbohrungen im Seitenteil nötig, dadurch ist ein Einrücken des Glastürflügels nach innen möglich und der Überstand (A) kann selbst bestimmt werden.

For glass-glass 90°, only drilled holes are required in the side panel, so that the glass door panel is set inwards and the overhang (A) can be determined by the installer.

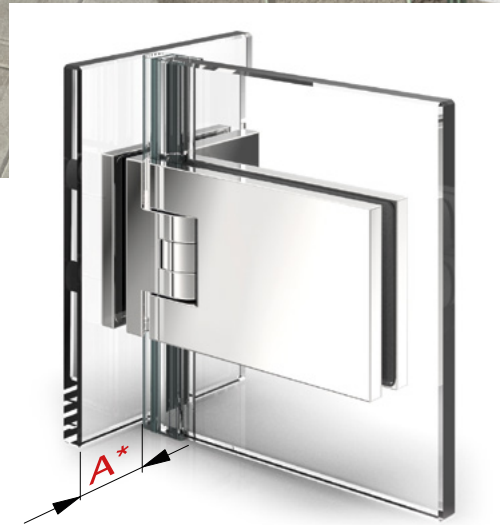

Die 7,5 mm dicke Wandanschraubplatte steht für eine bessere Lastabtragung und die 3. Befestigungsbohrung verhindert das Verdrehen der Beschläge auf der Wand. Das Duschband ist so konstruiert, dass diese Bohrung mit einem 8 mm Bohrer im montierten Zustand ausgeführt werden kann.

The 7.5 mm thick wall mounting plate provides better load transfer and the 3rd fixing hole prevents the fittings from twisting on the wall. The shower hinge is designed in such a way that this hole can be drilled with an 8 mm drill bit while mounted.



8900ZN Glas-Wand 90° | glass-wall 90°

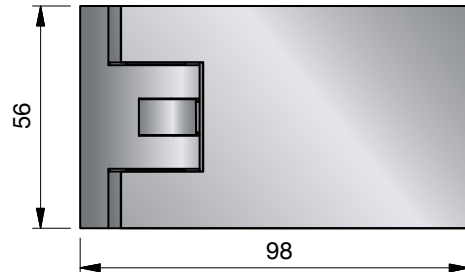

Art.-Nr. article no	Glasdicke glass thickness
8900_	6*/8/10* mm
Oberfläche finish:	
ZN5	glanzverchromt gloss chrome
ZN1	mattverchromt matt chrome
ZNPVD22	Edelstahloptik stainless steel optic
ZNPVD35	schwarz matt black matt
ZNPVD36	schwarz glänzend black gloss



beidseitig öffnend
opens inwards or outwards

Merkmale

beidseitig 90° öffnend, mit oder ohne Dichtprofil, verdeckte Verschraubungen, Wandbefestigung innen mit Langlochverstellung, Nulllage stufenlos und beliebig oft einstellbar, ab ca. 15° - 20° selbstschließend, Dichtprofil im Bandbereich unterbrochen

features

opens 90° inwards or outwards, with or without seal profile, concealed screws, wall mounting inside with oblong hole, closed position adjustable, self-closing at approx. 15° - 20°, seal profile notched in hinge area

***Wichtig**

Bei der Verwendung der Beschläge für 6 oder 10 mm Glasdicke bitte das Einlagenset Art. Nr. HZ-SET5 pro Beschlag kostenlos mitbestellen.

***important**

when using the hinges for 6 or 10 mm glass, please order the insert-set art. no. HZ-SET5 free of charge.

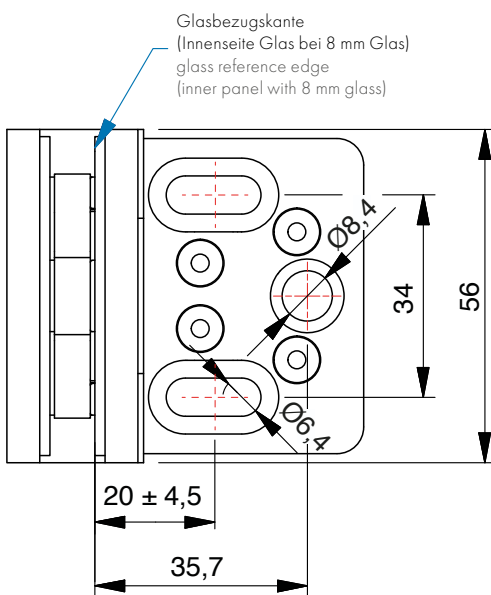

8900ZN Glas-Wand 90° | glass-wall 90°

MADE
IN
GERMANY

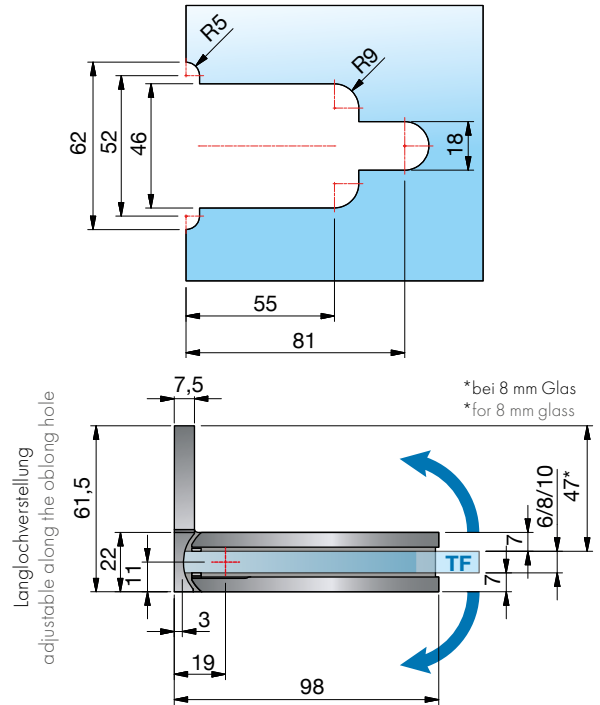

ohne Dichtprofil, für 8 mm Glas
without seal profile, for 8 mm glass

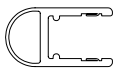

mit Dichtprofil | with seal profile
8861KU0-8-2010

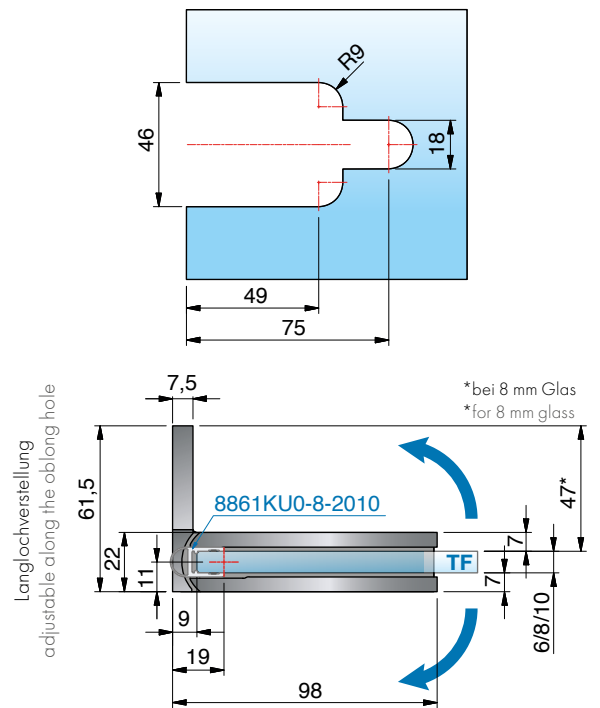

mit Dichtprofil 8861KU0-8-2010, für 8 mm Glas
with seal profile 8861KU0-8-2010, for 8 mm glass



8901ZN Glas-Glas 180° | glass-glass 180°

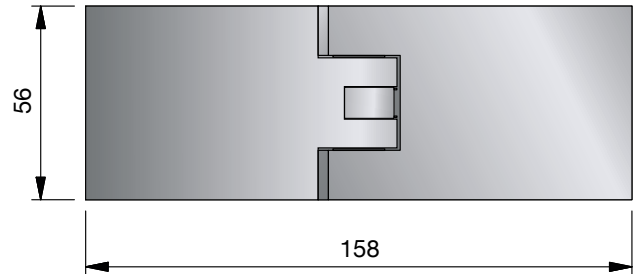

Art.-Nr. article no	Glasdicke glass thickness
8901_	6*/8/10* mm
Oberfläche finish:	
ZN5	glanzverchromt gloss chrome
ZN1	mattverchromt matt chrome
ZNPVD22	Edelstahloptik stainless steel optic
ZNPVD35	schwarz matt black matt
ZNPVD36	schwarz glänzend black gloss



Merkmale

beidseitig 90° öffnend, mit oder ohne Dichtprofil, verdeckte Verschraubungen, Nulllage stufenlos und beliebig oft einstellbar, ab ca. 15° - 20° selbstschließend, Dichtprofil im Bandbereich unterbrochen

features

opens 90° inwards or outwards, with or without seal profile, concealed screws, self-closing at approx. 15° - 20°, closed position adjustable, seal profile notched in hinge area

***Wichtig**

Bei der Verwendung der Beschläge für 6 oder 10 mm Glasdicke bitte das Einlagenset Art. Nr. HZ-SET6 pro Beschlag kostenlos mitbestellen.

***important**

when using the hinges for 6 or 10 mm glass, please order the insert-set art. no. HZ-SET6 free of charge.

beidseitig öffnend
opens inwards or outwards

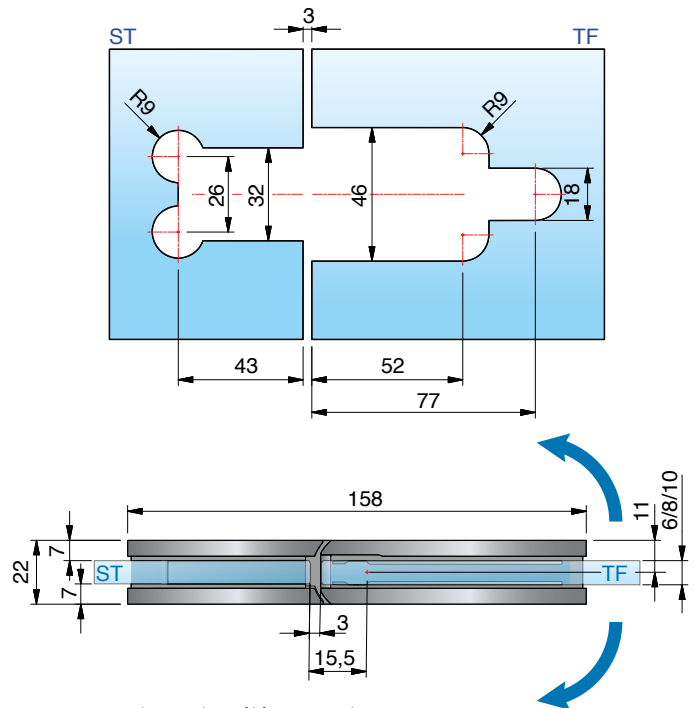

ohne Dichtprofil für 8 mm Glas
without seal profile, for 8 mm glass

8901ZN Glas-Glas 180° | glass-glass 180°

MADE
IN
GERMANY



mit Dichtprofil | with seal profile
8845KU0-8K-2500



beidseitig öffnend
opens inwards or outwards

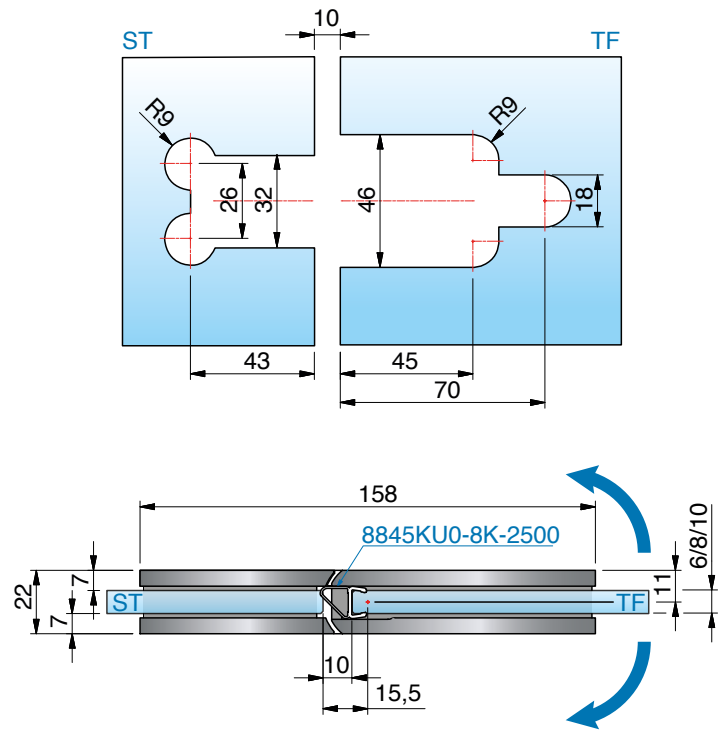

mit Dichtprofil 8845KU0-8K-2500, für 8 mm Glas
with seal profile 8845KU0-8K-2500, for 8 mm glass

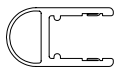

mit Dichtprofil | with seal profile
8861KU0-8-2010



beidseitig öffnend
opens inwards or outwards

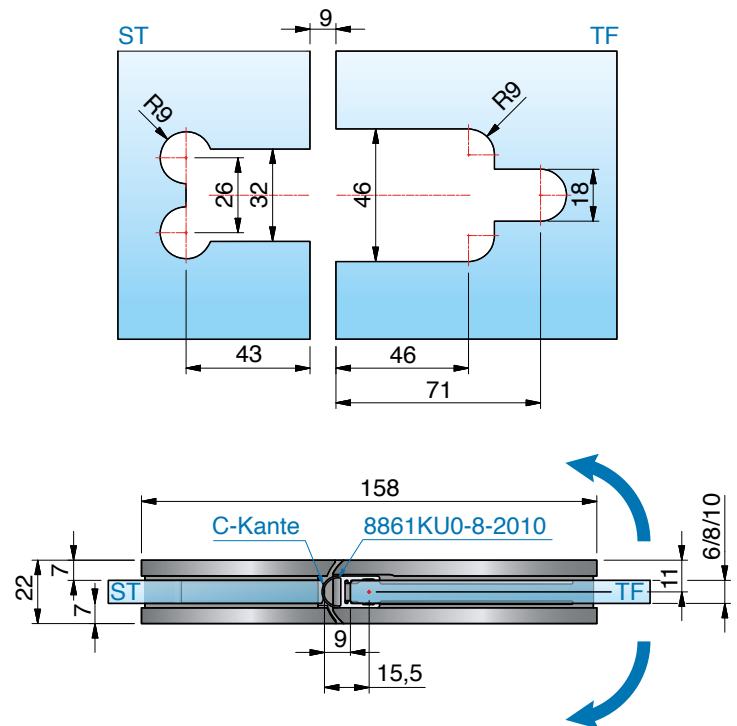

mit Dichtprofil 8861KU0-8-2010, für 8 mm Glas
with seal profile 8861KU0-8-2010, for 8 mm glass

8901ZN Glas-Glas 180° | glass-glass 180°

MADE
IN
GERMANY

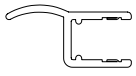

mit Dichtprofil | with seal profile
8857KU0-8-2010



aufgrund der Dichtung, nur nach außen zu öffnen!
due to the seal, only opens outwards!

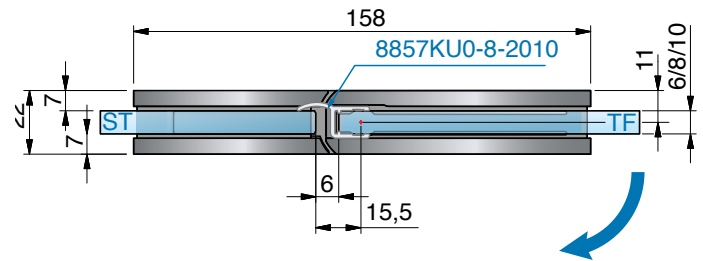
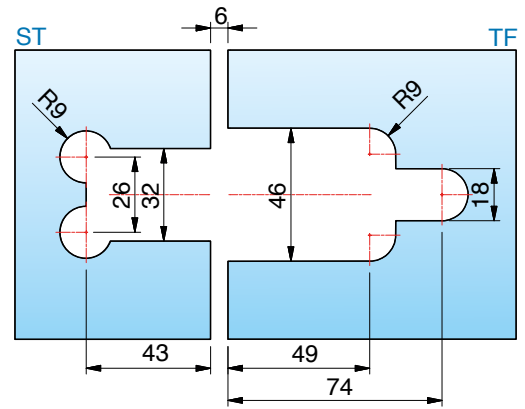

mit Dichtprofil 8857KU0-8-2010, für 8 mm Glas
with seal profile 8857KU0-8-2010, for 8 mm glass



8902ZN Glas-Glas 90° | glass-glass 90°

MADE
IN
GERMANY

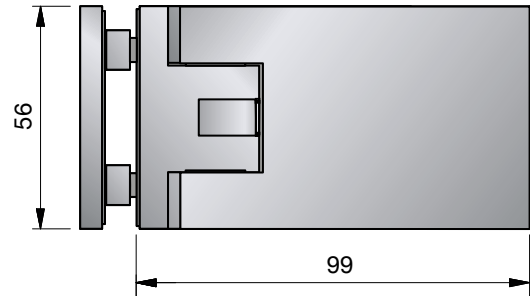

Art.-Nr. article no	Glasdicke glass thickness
8902_	6*/8/10* mm
Oberfläche finish:	
ZN5	glanzverchromt gloss chrome
ZN1	mattverchromt matt chrome
ZNPVD22	Edelstahloptik stainless steel optic
ZNPVD35	schwarz matt black matt
ZNPVD36	schwarz glänzend black gloss



beidseitig öffnend
opens inwards or outwards

Merkmale

beidseitig 90° öffnend, mit oder ohne Dichtprofil, verdeckte Verschraubungen, Null-lage stufenlos und beliebig oft einstellbar, ab ca. 15° - 20° selbstschließend, Dicht-profil im Bandbereich unterbrochen

features

opens 90° inwards or outwards, with or without seal profile, concealed screws, closed position adjustable, self-closing at approx. 15° - 20°, seal profile notched in hinge area

***Wichtig**

Bei der Verwendung der Beschläge für 6 oder 10 mm Glasdicke bitte das Einlagenset Art. Nr. HZ-SET5 pro Beschlag kostenlos mitbestellen.

***important**

when using the hinges for 6 or 10 mm glass, please order the insert-set art. no. HZ-SET5 free of charge.

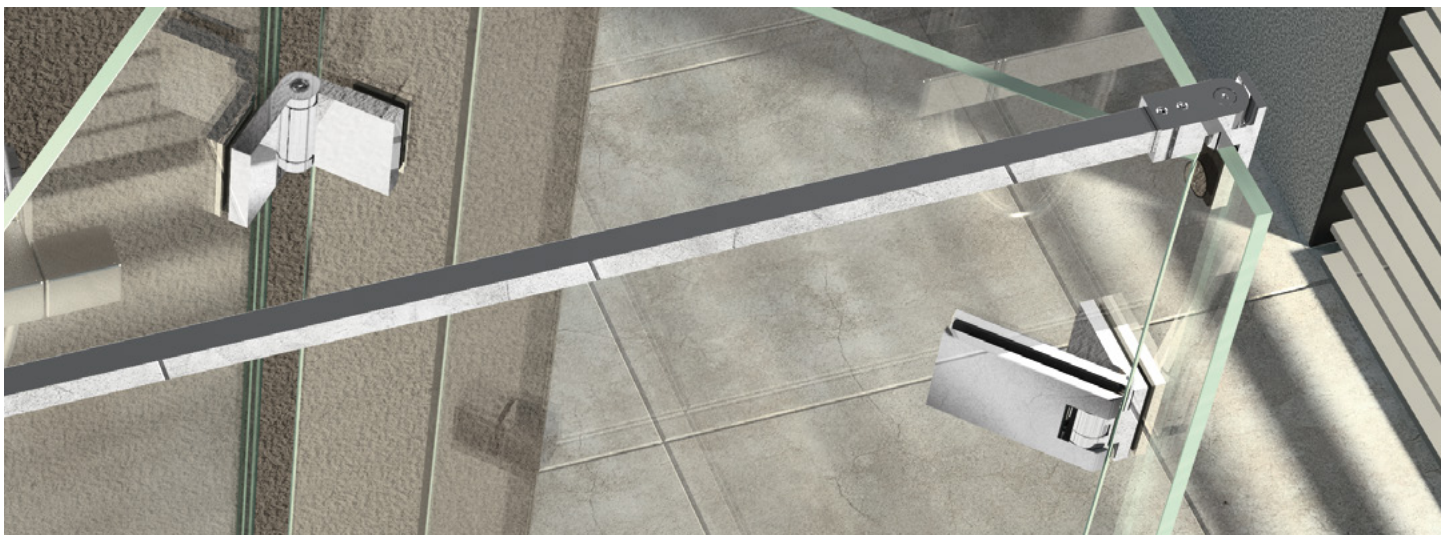

8902ZN Glas-Glas 90° | glass-glass 90°

MADE
IN
GERMANY

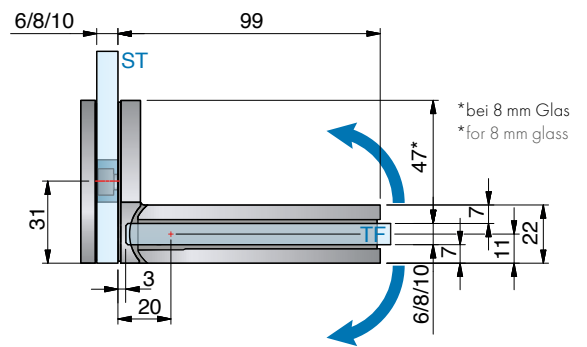
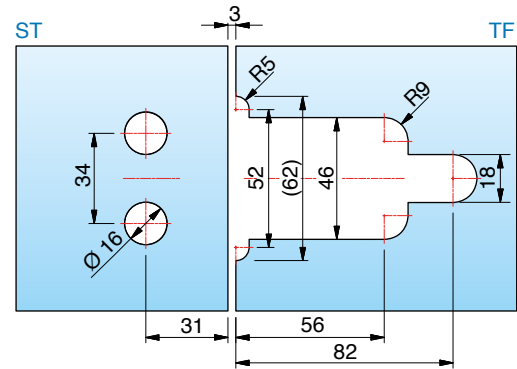
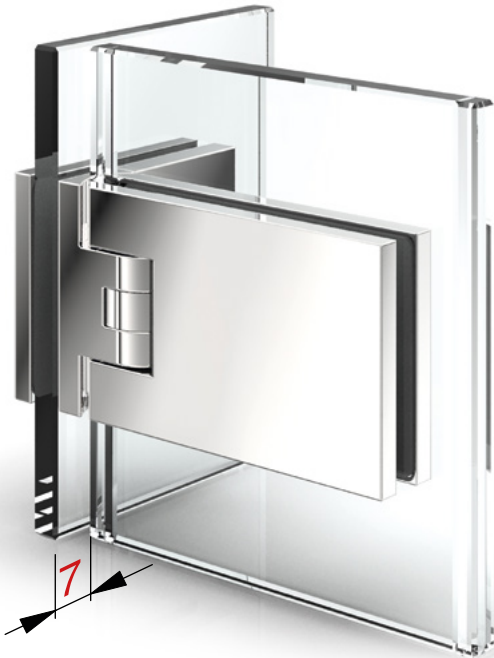

ohne Dichtprofil, für 8 mm Glas, 7 mm eingerückt
without seal profile, for 8 mm glass, 7 mm set inwards

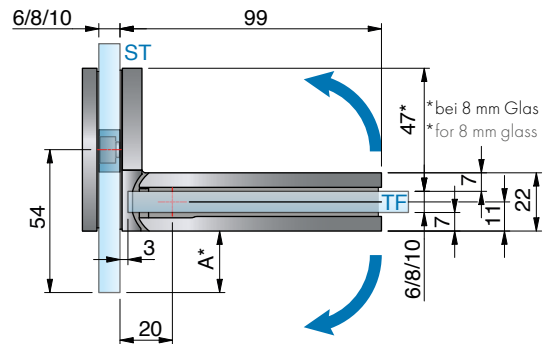
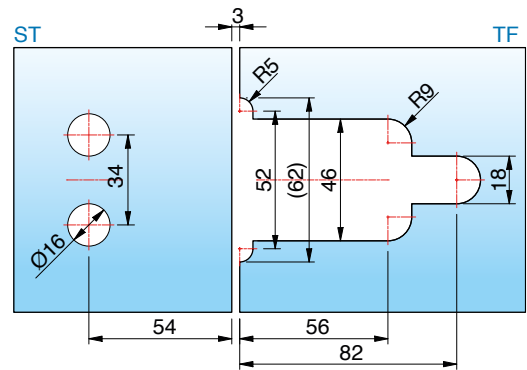
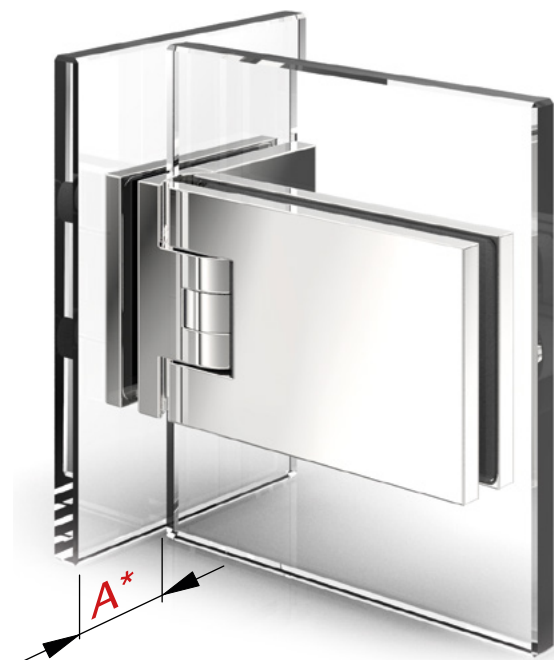

ohne Dichtprofil, für 8 mm Glas, Beispiel: 30 mm eingerückt
without seal profile, for 8 mm glass, example 30 mm set inwards

*Einrückmaß (A) am Seitenteil kann selbst bestimmt werden.
*offset dimension (A) on the side panel can be determined by the installer,

8902ZN Glas-Glas 90° | glass-glass 90°

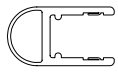

mit Dichtprofil | with seal profile
8861KU0-8-2010

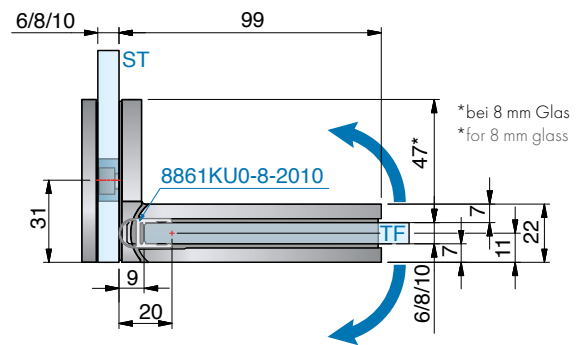
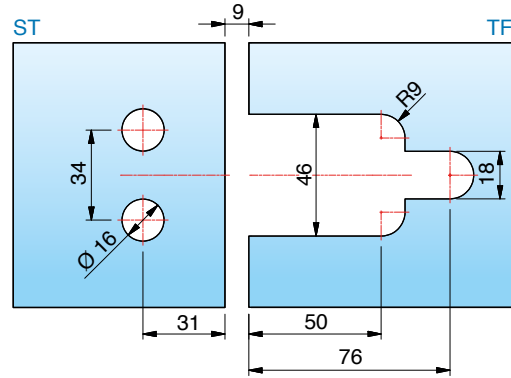

mit Dichtprofil 8861KU0-8-2010, für 8 mm Glas, 7 mm eingerückt
with seal profile 8861KU0-8-2010, for 8 mm glass, 7 mm set inwards

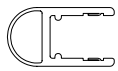

mit Dichtprofil | with seal profile
8861KU0-8-2010

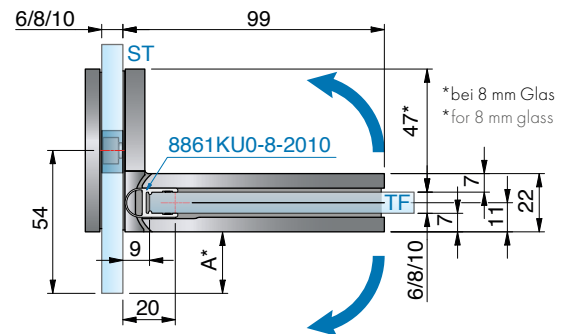
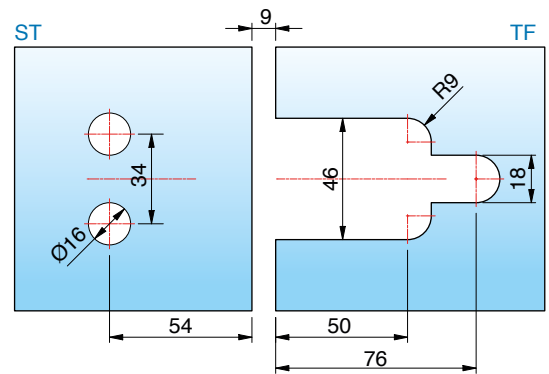
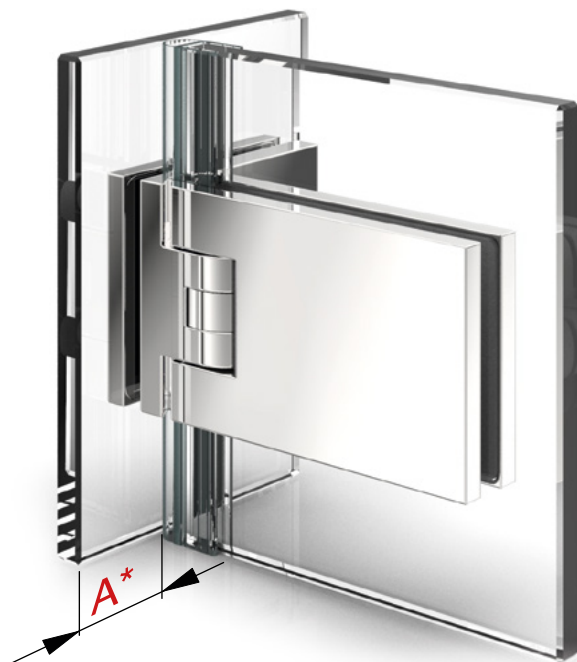

*Einrückmaß (A) am Seitenteil kann selbst bestimmt werden
*offset dimension (A) on the side panel can be determined by the installer

mit Dichtprofil 8861KU0-8-2010, für 8 mm Glas, Beispiel: 30 mm eingerückt
with seal profile 8861KU0-8-2010, for 8 mm glass, example 30 mm set inwards

Glas-Wand 90° | glass-wall 90°

MADE
IN
GERMANY



Art.-Nr. article no	Glasdicke glass thickness
8187_	6/8/10 mm
Oberfläche finish:	
ZN5	glanzverchromt gloss chrome
ZN1	mattverchromt matt chrome
ZNPVD22	Edelstahloptik stainless steel optic
ZNPVD35	schwarz matt black matt
ZNPVD36	schwarz glänzend black gloss



Merkmale
verdeckte Verschraubungen mit Abdeckkappe
features
concealed screws with cover plate

Art.-Nr. article no	Glasdicke glass thickness
8178_	8/10 mm
Oberfläche finish:	
ZN5	glanzverchromt gloss chrome
ZN1	mattverchromt matt chrome
ZNPVD22	Edelstahloptik stainless steel optic



Merkmale
ohne Befestigungslasche, inkl. Befestigungsschraube
sichtbare Verschraubung
features
without mounting plate, mounting screw included
visible screws

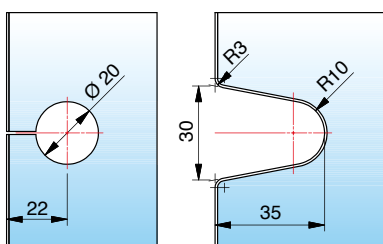
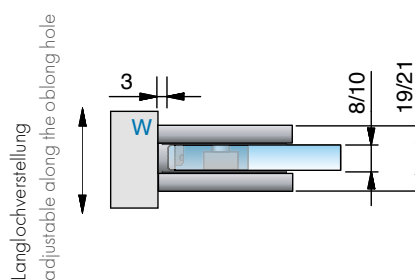
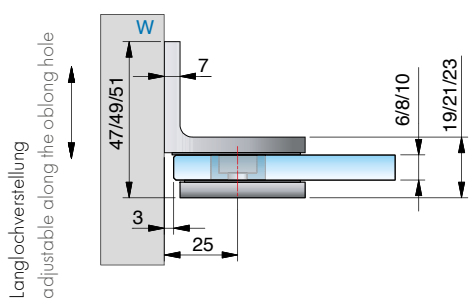

Glasbearbeitung für 6/8/10 mm, Bohrung Ø20 mm oder Randausschnitt R35
glass processing for 6/8/10 mm, hole Ø20 mm or recess R35

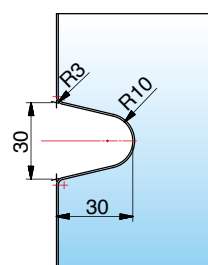

Glasbearbeitung für 8 mm
glass processing for 8 mm

Glas-Wand 90° | glass-wall 90°



Art.-Nr. article no	Glasdicke glass thickness	Merkmale	features
8171_	6/8/10 mm	verstellbarer Winkel (60° - 100°), sichtbare Verschraubung	adjustable angle (60° - 100°), visible screws
Oberfläche finish:			
ZN5	glanzverchromt gloss chrome		
ZN1	mattverchromt matt chrome		
ZNPVD22	Edelstahloptik stainless steel optic		

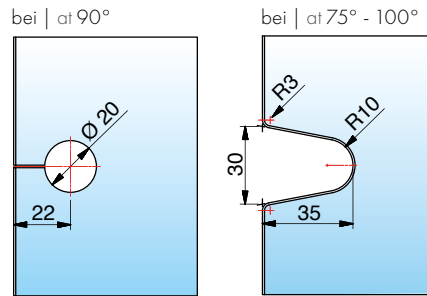
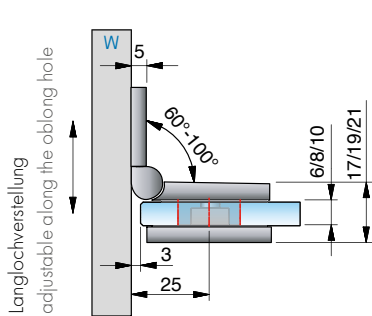

Glasbearbeitung für 6/8/10 mm, Bohrung Ø20 mm oder Randausschnitt R35
glass processing for 6/8/10 mm, hole Ø22 mm or recess R35

Gehungswinkel und Bohrlochmaße für 8171ZN miter angle and hole dimensions for 8171ZN			
Winkel corner	Bohrlochmaß von Glaskante hole dimensions from glass edge	Gehungswinkel am Glas miter angle	Bemerkung remarks
60°	29 mm	30°	-
65°	28 mm	25°	-
70°	26 mm	20°	-
75°	25 mm	15°	Bohrung geschlitzt hole slotted
80°	24 mm	10°	Bohrung geschlitzt hole slotted
85°	23 mm	5°	Bohrung geschlitzt hole slotted
90°	22 mm	ohne Gehung without miter	Bohrung geschlitzt hole slotted
95°	21 mm	5°	Bohrung geschlitzt hole slotted
100°	21 mm	10°	Bohrung geschlitzt hole slotted

Glas-Wand 135° | glass-wall 135°



Art.-Nr. article no	Glasdicke glass thickness	Merkmale	features
8173_	6/8/10 mm	Winkelgradzahl stufenlos von 100° - 140° verstellbar sichtbare Verschraubung	degree of angle is infinitely adjustable between 100° - 140° visible screws

Oberfläche finish:	
ZN5	glanzverchromt gloss chrome
ZN1	mattverchromt matt chrome
ZNPVD22	Edelstahloptik stainless steel optic

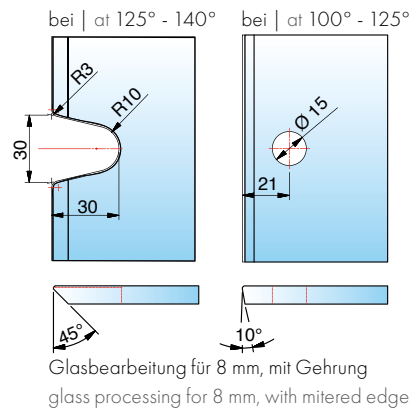
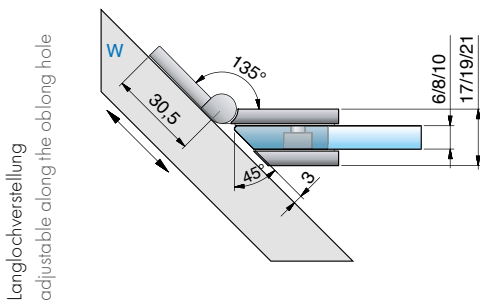

Gehrungswinkel und Bohrlochmaße für 8173ZN			
miter angle and hole dimensions for 8173ZN			
Winkel corner	Bohrlochmaß von Glaskante hole dimensions from glass edge	Gehrungswinkel am Glas miter angle	Bemerkung remarks
100°	21 mm	10°	Bohrung geschlitzt hole slotted
105°	20 mm	15°	
110°	19 mm	20°	
115°	19 mm	25°	
120°	18 mm	30°	
125°	17 mm	35°	Bohrung geschlitzt o. Randausschnitt R30 hole slotted o. edge recess R30
130°	-	40°	Randausschnitt R30 edge recess R30
135°	-	45°	Randausschnitt R30 edge recess R30
140°	-	50°	Randausschnitt R30 edge recess R30

Glas-Wand 180° | glass-wall 180°

Glas-Glas 90° | glass-glass 90°



Art.-Nr. article no	Glasdicke glass thickness
8174_	6/8/10 mm
Oberfläche finish:	
ZN5	glanzverchromt glass chrome
ZN1	mattverchromt matt chrome
ZNPVD22	Edelstahloptik stainless steel optic



Art.-Nr. article no	Glasdicke glass thickness
8188_	6/8/10 mm
Oberfläche finish:	
ZN5	glanzverchromt glass chrome
ZN1	mattverchromt matt chrome
ZNPVD22	Edelstahloptik stainless steel optic
ZNPVD35	schwarz matt black matt
ZNPVD36	schwarz glänzend black gloss



Merkmale | features
 Wandbefestigung mit Langlochverstellung, mit Abdeckplatte sichtbare Verschraubung
 wall mounting with oblong hole with cover plate visible screws

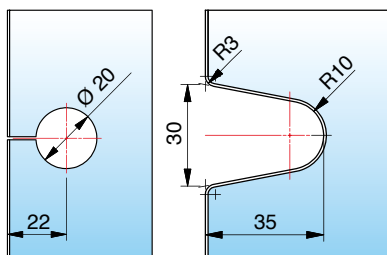
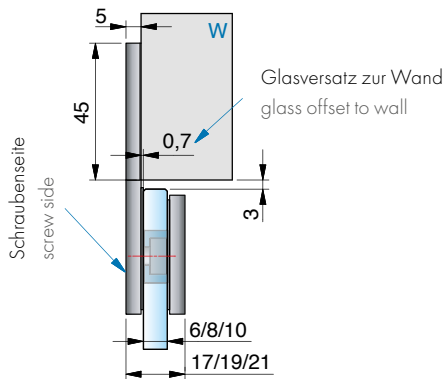

Glasbearbeitung für 6/8/10 mm, Bohrung Ø20 mm oder Randausschnitt R35
 glass processing for 6/8/10 mm, hole Ø22 mm or recess R35

Merkmale | features
 verdeckte Verschraubungen mit Abdeckplatte
 concealed screws with cover plate

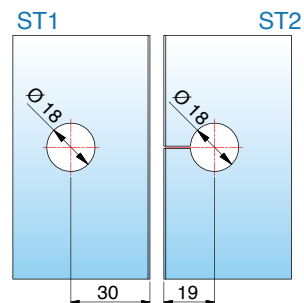
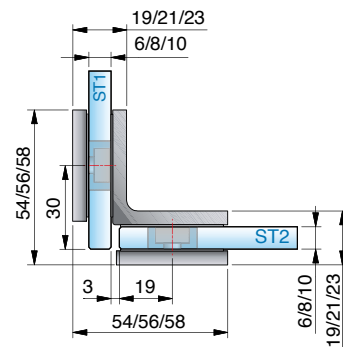

Glasbearbeitung für 6/8/10 mm Glas
 glass processing for 6/8/10 mm glass

Glas-Glas 90° | glass-glass 90°



Art.-Nr. article no	Glasdicke glass thickness
8175_	6/8/10 mm
Oberfläche finish:	
ZN5	glanzverchromt gloss chrome
ZN1	mattverchromt matt chrome
ZNPVD22	Edelstahloptik stainless steel optic



Merkmale

Winkelgradzahl stufenlos von 80° - 180° verstellbar
sichtbare Verschraubung

features

degree of angle is infinitely adjustable between 80° - 180°
visible screws

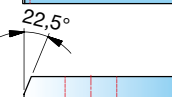
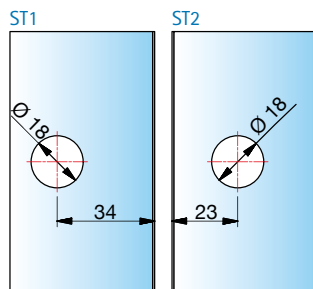
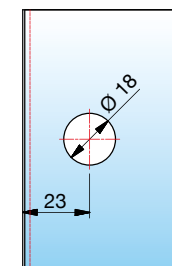
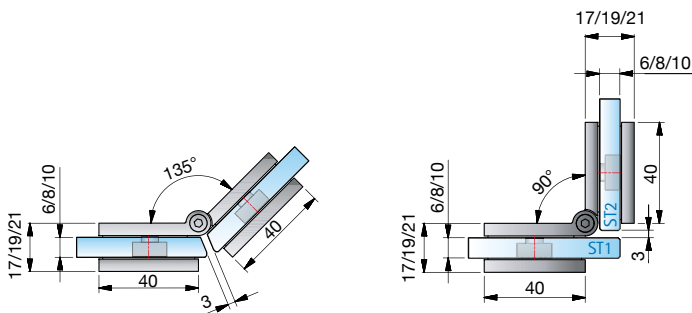

Glasbearbeitung für 8 mm, mit Gehrung
glass processing for 8 mm, with mitered edge

Gehrungswinkel und Bohrlochmaße für 8175ZN

miter angle and hole dimensions for 8175ZN

Winkel corner	Bohrlochmaß von Glaskante hole dimensions from glass edge	Gehrungs- winkel am Glas miter angle	Bemerkung remarks
80°	32 mm	50°	-
85°	31 mm	47,5°	-
90°	30 mm	45°	-
95°	29 mm	42,5°	-
100°	28 mm	40°	Bohrung geschlitzt hole slotted
105°	27 mm	37,5°	Bohrung geschlitzt hole slotted
110°	26 mm	35°	Bohrung geschlitzt hole slotted
115°	26 mm	32,5°	Bohrung geschlitzt hole slotted
120°	25 mm	30°	Bohrung geschlitzt hole slotted
125°	24 mm	27,5°	Bohrung geschlitzt hole slotted
130°	24 mm	25°	Bohrung geschlitzt hole slotted
135°	23 mm	22,5°	Bohrung geschlitzt hole slotted
140°	23 mm	20°	Bohrung geschlitzt hole slotted
145°	22 mm	17,5°	Bohrung geschlitzt hole slotted
150°	22 mm	15°	Bohrung geschlitzt hole slotted
155°	21 mm	12,5°	Bohrung geschlitzt hole slotted
160°	21 mm	10°	Bohrung geschlitzt hole slotted
165°	20 mm	7,5°	Bohrung geschlitzt hole slotted
170°	20 mm	5°	Bohrung geschlitzt hole slotted
175°	19 mm	0°	Bohrung geschlitzt hole slotted
180°	19 mm	0°	Bohrung geschlitzt hole slotted



Falttüranlage | folding door system

MADE
IN
GERMANY



Faltdüranlage | folding door system

FARDELLO ist der Beschlag mit hoher Tragkraft, FLINTER das Kraftpaket mit intelligenter Federtechnik – zwei Beschläge aus unterschiedlichen Serien. Miteinander kombiniert, lassen sich verschiedene Badewannen- und Faltdüranlagen umsetzen. Einfach und unkompliziert in der Planung und Realisierung – mit der Fachexpertise von Pauli + Sohn.

FARDELLO is the hinge with high load capacity, FLINTER is the power pack with intelligent spring loading technology - two hinges from different series. Combined, they can be implemented for various bathtub and folding door systems. Simple and uncomplicated in planning and implementation - with the technical competence of Pauli + Sohn.



FARDELLO

Art.-Nr. article no	Glasdicke glass thickness
8900ZN	6/8/10 mm

Hinweis: Bestimmen Sie selbst die Stärke der Zuhaltkraft Ihrer Tür über die Anzahl der Federn. 0-3 Federn erhältlich – siehe Duschenwelt Rubrik Serie Flinter

FLINTER

Art.-Nr. article no	Glasdicke glass thickness
8160ZN	6/8/10 mm

note: you can determine the strength of the locking force of your door by the number of springs. 0-3 springs available - see our shower world catalog, series Flinter



Abmessungen Faltranlagen Glas-Wand | folding systems dimensions glass-wall



Faltranlage: 8900ZN ohne Dichtprofil und
 folding system: 8160ZN mit Dichtprofil 8865KU0
 8900ZN without seal profile and
 8160ZN with seal profile 8865KU0

Faltranlage: 8900ZN mit Dichtprofil 8861KU0 und
 folding system: 8160ZN mit Dichtprofil 8861KU0
 8900ZN with seal profile 8861KU0 and
 8160ZN with seal profile

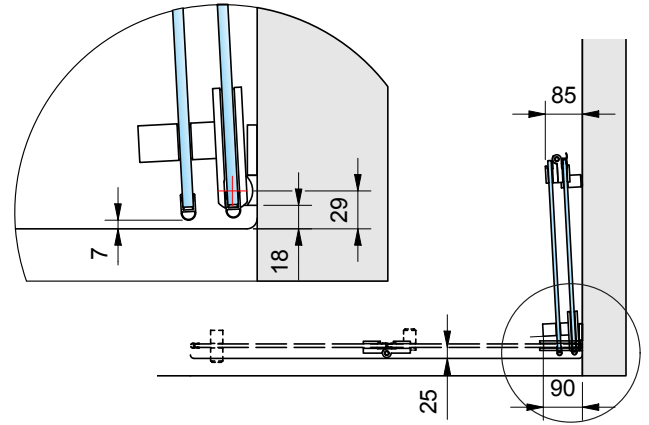
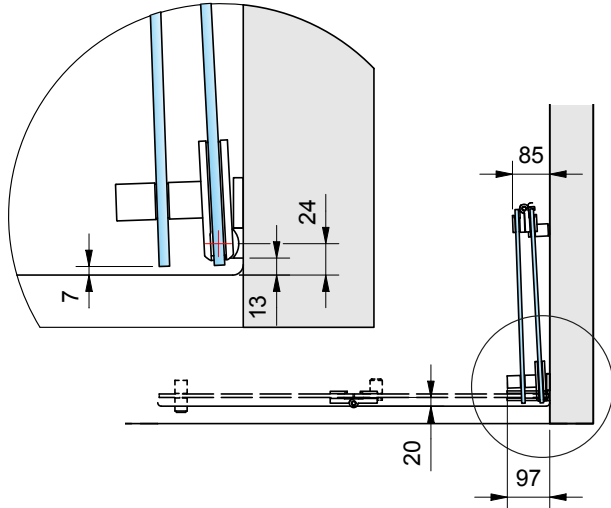

Abmessungen Faltranlagen Glas-Glas | folding systems dimensions glass-glass

Faltranlage: 8902ZN ohne Dichtprofil und
folding system: 8160ZN mit Dichtprofil 8865KU0
8902ZN without seal profile and
8160ZN with seal profile 8865KU0

Faltranlage: 8902ZN mit Dichtprofil 8861KU0 und
folding system: 8160ZN mit Dichtprofil 8861KU0
8902ZN with seal profile 8861KU0 and
8160ZN with seal profile 8861KU0

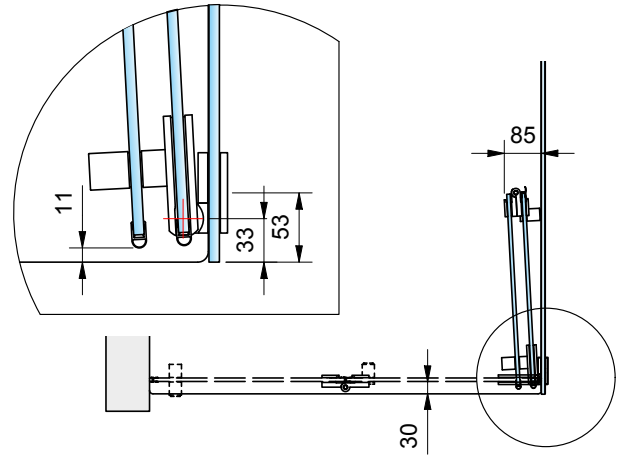
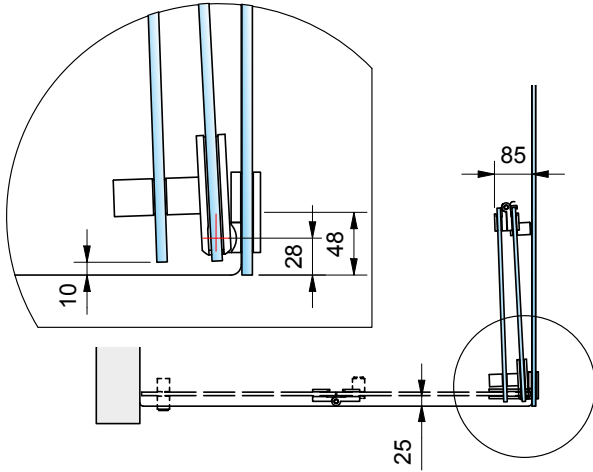

Faltrüranlage - Die maximale Tragfähigkeit für die jeweiligen Duschtürbänder ist zu beachten.

folding door system - the maximum load capacity for the respective shower door hinges must be observed.

Wir empfehlen diese Dichtprofile für Faltrüren:
we recommend the seal profile:

Bohrlochabstände für:
hole spacing for:

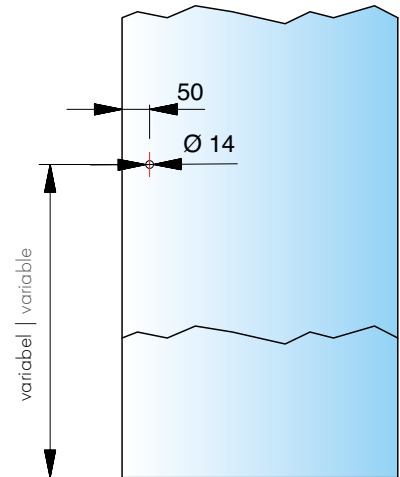
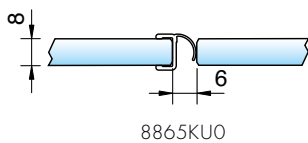
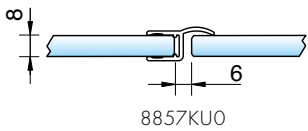

Hinweis: Glstürgriffe mit Gummianschlag siehe Seite 26
note: glass door knobs on page 26

Stabilisierungswinkel | stabilizing angle bracket

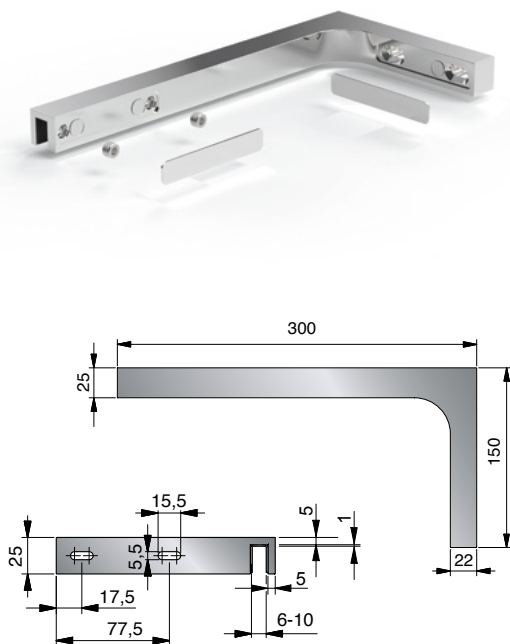

Merkmale

Stabilisierungswinkel mit Langlochverstellung an der Wandseite, aufsteckbar auf Glasoberkante, keine Glasbearbeitung, verdeckte Verschraubung

features

stabilizing angle bracket with oblong hole for adjustment on the wall side, attachable to the top edge of the glass, no glass processing necessary, concealed screws

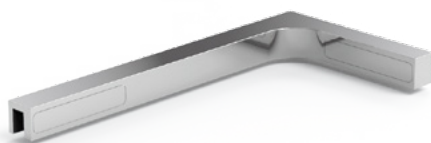

Stabilisierungswinkel stabilizing angle bracket	
Art.-Nr. article no	Glasdicke glass thickness
8449_-L	6/8/10 mm
Oberfläche finish:	
MS7	glanzverchromt gloss chrome
MS10	mattverchromt matt chrome
MSPVD22	Edelstahloptik stainless steel optic
MSPVD35	schwarz matt black matt
MSPVD36	schwarz glänzend black gloss

Stabilisierungswinkel stabilizing angle bracket	
Art.-Nr. article no	Glasdicke glass thickness
8449_-R	6/8/10 mm
Oberfläche finish:	
MS7	glanzverchromt gloss chrome
MS10	mattverchromt matt chrome
MSPVD22	Edelstahloptik stainless steel optic
MSPVD35	schwarz matt black matt
MSPVD36	schwarz glänzend black gloss

Nischenduschen
niche showers



Nischenduschen
niche showers



Eckduschen
corner showers



Fünfeckduschen*
pentagonal showers*



Badewannen
bathtubs



*nicht mit Fardello möglich
*not possible with Fardello

Überdrückungsschutz | door stop

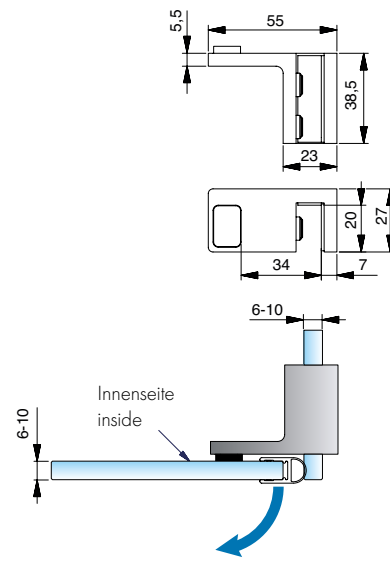
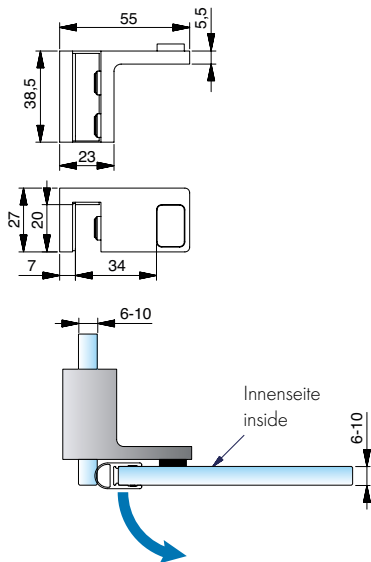
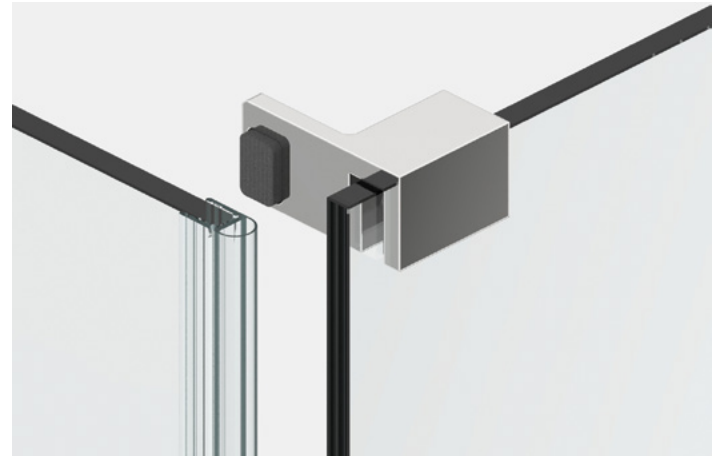
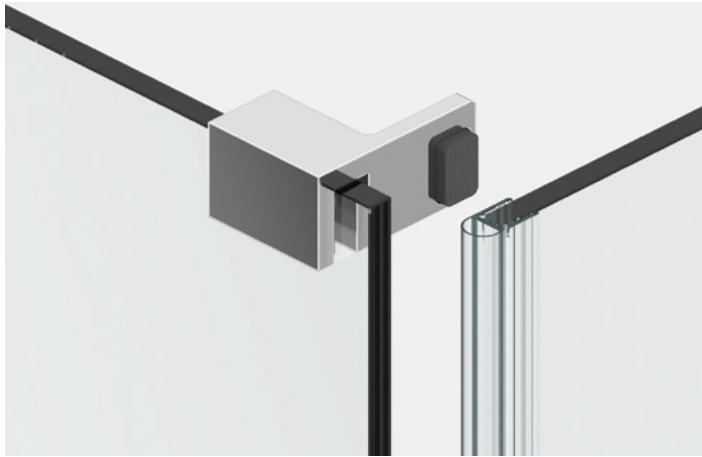

Überdrückungsschutz links 90° door stop left 90°	
Art.-Nr. article no	Glasdicke glass thickness
8489_L	6/8/10 mm
Oberfläche finish:	
MS7	glanzverchromt gloss chrome

Überdrückungsschutz rechts 90° door stop right 90°	
Art.-Nr. article no	Glasdicke glass thickness
8489_R	6/8/10 mm
Oberfläche finish:	
MS7	glanzverchromt gloss chrome

Flächenbündiger Anschluss-Adapter | flush-mounted connection adapter

DESIGNED
IN
GERMANY

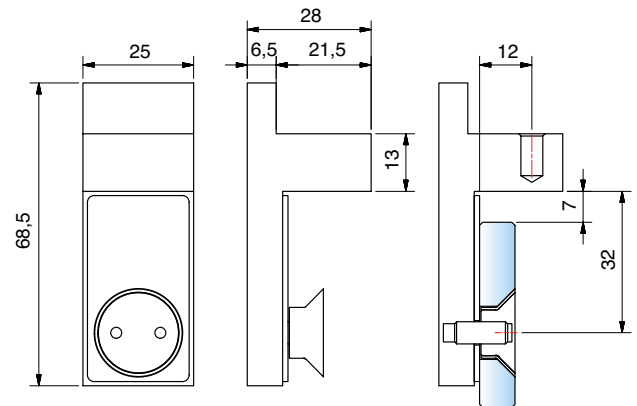

Flächenbündiger Anschluss-Adapter für Stabilisationsstange 8474
flush-mounted connection adapter for support rod 8474

Art.-Nr. article no	Glasdicke glass thickness
8471_	8/10 mm

Oberfläche | finish:

MS7 glanzverchromt | gloss chrome

MS10 mattverchromt | matt chrome

MSPVD35 schwarz matt | black matt

MSPVD36 schwarz glänzend | black gloss

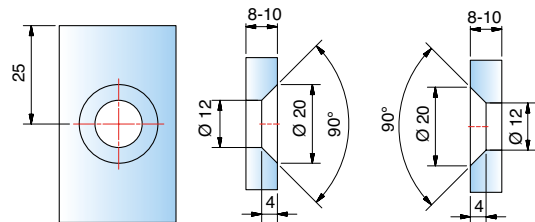

Wichtig

Um das beidseitige Öffnen und Heben (PAVONE) des Türflügels zu gewährleisten, empfehlen wir die Verwendung dieses flächenbündigen Adapters.

To ensure that the door panel opens inwards and outwards and lifts (PAVONE), we recommend using this flush mounted adapter.

important

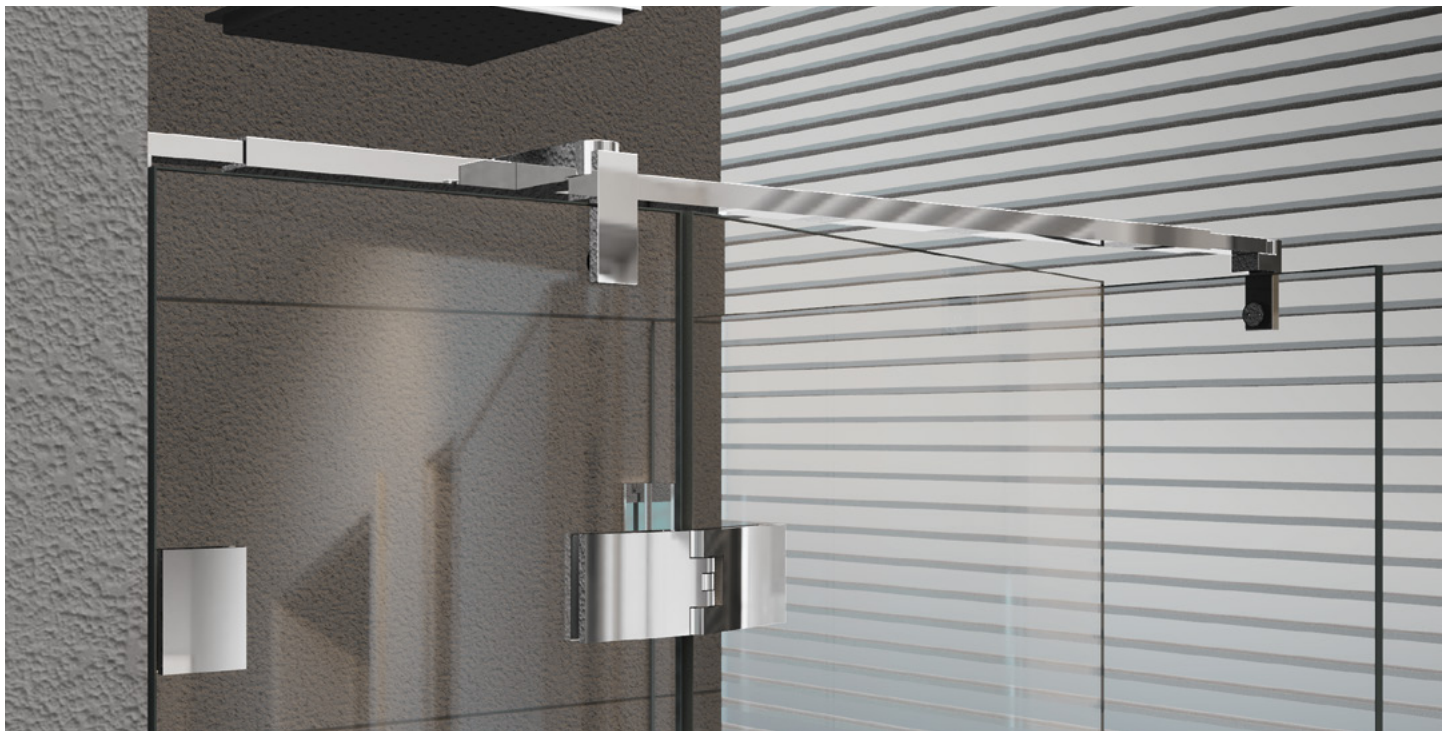

Flächenbündiger Anschluss-Adapter | flush-mounted connection adapter

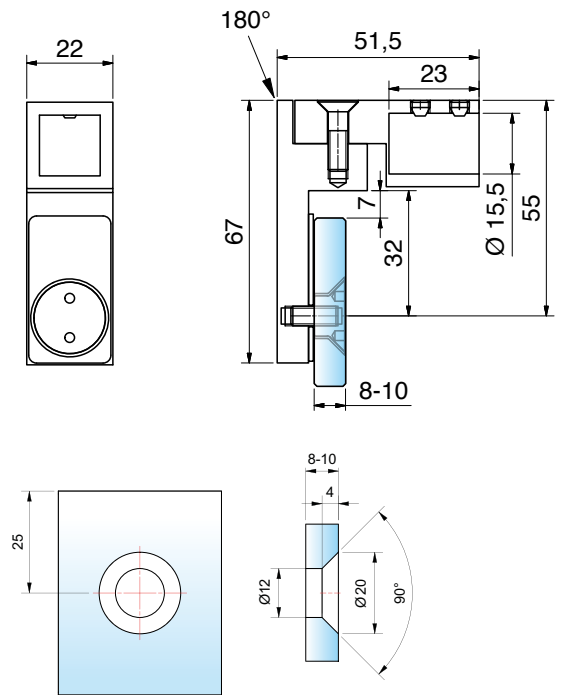

Flächenbündiger Anschluss-Adapter für Stabilisationsstange 8688
flush-mounted connection adapter for support rod 8688

Art.-Nr. | article no Glasdicke | glass thickness

8494_-GF 8/10 mm

Oberfläche | finish:

MS7 glanzverchromt | gloss chrome

MS10 mattverchromt | matt chrome

MSPVD35 schwarz matt | black matt

MSPVD36 schwarz glänzend | black gloss



Hinweis
Weiteres Zubehör siehe Katalog: Duschenwelt

note
for more accessories see our shower world catalog

Glastürgriffe mit Gummianschlag | glass door knob with rubber stop

DESIGNED
IN
GERMANY

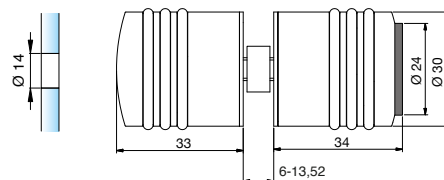
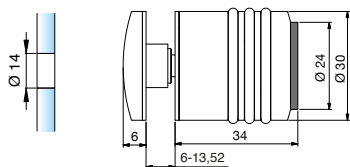

Glastürgriff einseitig, mit Gummianschlag glass door knob one sided, with rubber stop	
Art.-Nr. article no	Glasdicke glass thickness
8293_	6 - 13,52 mm
Oberfläche finish:	
ZN5	glanzverchromt gloss chrome
ZN1	mattverchromt matt chrome
ZNPVD22	Edelstahloptik stainless steel optic
ZNPVD35	schwarz matt black matt
ZNPVD36	schwarz glänzend black gloss

Glastürgriff beidseitig, mit Gummianschlag glass door knob double sided, with rubber stop	
Art.-Nr. article no	Glasdicke glass thickness
8294_	6 - 13,52 mm
Oberfläche finish:	
ZN5	glanzverchromt gloss chrome
ZN1	mattverchromt matt chrome
ZNPVD22	Edelstahloptik stainless steel optic
ZNPVD35	schwarz matt black matt
ZNPVD36	schwarz glänzend black gloss

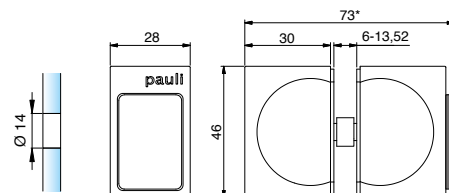
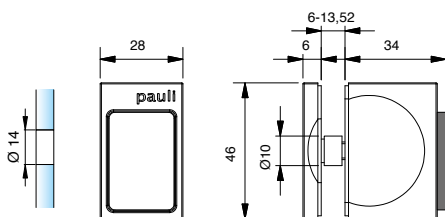

Glastürgriff einseitig, mit Gummianschlag glass door knob one sided, with rubber stop	
Art.-Nr. article no	Glasdicke glass thickness
8271_	6 - 13,52 mm
Oberfläche finish:	
ZN5	glanzverchromt gloss chrome
ZN1	mattverchromt matt chrome
ZNPVD22	Edelstahloptik stainless steel optic
ZNPVD35-A	schwarz matt black matt (ohne Logo without logo)
ZNPVD36-A	schwarz glänzend black gloss (ohne Logo without logo)

Glastürgriff beidseitig, mit Gummianschlag glass door knob double sided, with rubber stop	
Art.-Nr. article no	Glasdicke glass thickness
8273_	6 - 13,52 mm
Oberfläche finish:	
ZN5	glanzverchromt gloss chrome
ZN1	mattverchromt matt chrome
ZNPVD22	Edelstahloptik stainless steel optic
ZNPVD35	schwarz matt black matt
ZNPVD36-A	schwarz glänzend black gloss (ohne Logo without logo)

Art.-Nr. P10-34-20 Version 6
Alle Bilder, technische Zeichnungen und deren Beschreibungen sind urheberrechtlich geschütztes Eigentum der Pauli + Sohn GmbH. Technische Maßangaben innerhalb des Kataloges sind unverbindlich. Konstruktionsänderungen sind vorbehalten. Bitte beachten Sie unsere Schutzrechte. Für Druckfehler und Irrtümer, die bei der Herstellung unterlaufen sind, ist jede Haftung ausgeschlossen.

www.pauli.de

Technischer Stand: November 2023

art.-no. P10-34-20 edition 6
All images, technical drawings and descriptions are copyrighted property of the Pauli + Sohn GmbH. Technical measurements within the catalog are not binding and are subject to change. Any liability for printing errors which have occurred during the preparing of this brochure is excluded.

www.pauli.de/technical

status: november 2023



Pauli + Sohn GmbH

Werk I:

Eisenstraße 2

D-51545 Waldbröl

Telefon: +49 (0) 22 91-92 06-0

Fax: +49 (0) 22 91-92 06-681

Werk II:

Industriestraße 20

D-51597 Morsbach

Telefon: +49 (0) 22 94-98 03-0

Fax: +49 (0) 22 94-98 03-881

www.pauli.de

info@pauli.de